



University of Ruhuna

Wellamadama

Matara.

02.09.2024

The Manager

.....
.....
.....
.....

Invitation for Bids (IFB)

**Contract: Supply, Delivery, Installation, Commissioning, Testing and Maintenance Furniture
- RUH/SUP/2024/S6/071**

1. The Chairman, Department Procurement Committee on behalf of the University of Ruhuna now invites sealed bid from you for **Supply, Delivery, Installation, Commissioning, Testing and Maintenance of Furniture** indicated in the annexed biddocument.
2. Bidding will be conducted through National Shopping method of procurement.
3. You may obtain further information if any from the **Deputy Bursar/ Supplies**, University of Ruhuna, Wellamadama, Matara. (T/P 041- 2227027 / 041-2033263
e-mail : sabs@admin.ruh.ac.lk
4. Bids must be delivered by mail in sealed envelopes addressed to **Deputy Bursar (Supplies)**, University of Ruhuna, Wellamadama, Matara before **02.00p.m on 19.09.2024**
Late bids will be rejected.
5. This contract is subject to
 - I. Providing of Performance Security of 10% of the total contract price in accordance with the format given by us and issued in favor of the Vice Chancellor, University of Ruhuna.
 - II. Entering into a formal agreement with the University of Ruhuna.
6. Sample should provide if request by the university.
7. Please mention delivery period.
8. Please mention availability of the stock.

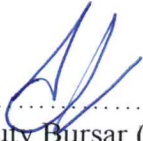
.....

Deputy Bursar (Supplies)
University of Ruhuna,
Wellamadama,
Matara.



UNIVERSITY OF RUHUNA

**PROCUREMENT OF GOODS UNDER
NATIONAL SHOPPING PROCEDURES**

**INVITATION FOR QUOTATIONS
FOR**

**SUPPLY, DELIVERY, INSTALLATION, COMMISSIONING,
TESTING AND MAINTENANCE OF
FURNITURE**

IFQ No: RUH/SUP/2024/S6/071

Section I. Instructions to Vendors (ITV)

A:General	
1. Scope of Bid	1.1 The Purchaser named in the Data Sheet invites you to submit a quotation for the supply of Goods as specified in Section III Schedule of Requirements.
B:Contents of Documents	
2. Contents of Documents	<p>The documents consist of the Sections indicated below.</p> <ul style="list-style-type: none"> • Section I. Instructions to Vendors (ITV) • Section II. Data Sheet • Section III. Schedule of Requirements • Section IV. Technical Specifications & Compliance with Specifications • Section V. Quotation submission Form(s)
C:Preparation of Quotation	
3. Documents Comprising your Quotation	<p>The Quotation shall comprise the following:</p> <ul style="list-style-type: none"> (a) Quotation Submission Form and the Price Schedules; (b) Technical Specifications & Compliance with Specifications
4. Quotation Submission Form and Price Schedules	<p>The vendor shall submit the Quotation Submission Form using the form furnished in Section V. This form must be completed without any alterations to its format, and no substitutes shall be accepted. All blank spaces shall be filled in with the information requested.</p> <p>Alternative offers shall not be considered. The vendors are advised not to quote different options for the same item but furnish the most competitive among the options available to the bidder.</p>
5. Prices and Discounts	<p>Unless specifically stated in Data Sheet, all items must be priced separate in the Price Schedules.</p> <p>The price to be quoted in the Quotation Submission Form shall be the total price of the Quotation, including any discounts offered.</p>

	<p>The applicable VAT shall be indicated separately.</p> <p>Prices quoted by the vendor shall be fixed during the vendor's performance of the Contract and not subject to variation on any account. A Quotation submitted with adjustable price shall be treated as non responsive and maybe rejected.</p>
6. Currency	6.1 The vendors shall quote only in Sri Lanka Rupees.
7. Documents to Establish the Conformity of the Goods	<p>7.1 The vendor shall furnish as part of its quotation the documentary evidence that the Goods conform to the technical specifications and standards specified in Section IV, "Technical Specifications & Compliance with Specifications".</p> <p>7.2 The documentary evidence maybe in the form of literature, drawings or data, and shall consist of a detailed item by item description of the essential technical and performance characteristics of the Goods, demonstrating substantial responsiveness of the Goods to the technical specifications, and if applicable, a statement of deviations and exceptions to the provisions of the Technical Specifications given.</p> <p>7.3 If stated in the Data Sheet the vendor shall submit a certificate from the manufacturer to demonstrate that it has been duly authorized by the manufacturer or producer of the Goods to supply these Goods in Sri Lanka.</p>
8. Period of Validity of quotation	8.1 Quotations shall remain valid for the period of ninety (90) days after the quotation submission deadline date.
9. Format and Signing of Quotation	9.1 The quotation shall be typed or write and shall be signed by a person duly authorized to sign on behalf of the vendor.
D: Submission and Opening of Quotation	
10. Submission of Quotation	<p>Vendors may submit their quotations by sealed envelopes addressed to the Purchaser and bear the specific identification of the quotation number.</p> <p>If the quotation is not sealed and marked as required, the Purchaser will assume no responsibility for them is placement or premature opening of the quotation.</p>
11. Deadline for Submission of Quotation	11.1 Quotation must be received by the Purchaser at the address set out in Section II, Data Sheet", and not later than the date and time as specified in the Data Sheet.
12. Late Quotations	12.1 The Purchaser shall reject any quotation that arrives after the Deadline for submission of quotations, in accordance with ITV Clause 11.1 above.

<p>13. Opening of Quotations</p>	<p>13.1 The Purchaser shall conduct the opening of quotation in public at the address, date and time specified in the Data Sheet.</p> <p>13.2 A representative of the bidders may be present and mark his attendance.</p>
<p>E: Evaluation and Comparison of Quotations</p>	
<p>14. Clarifications</p>	<p>14.1 To assist in the examination, evaluation and comparison of the quotations, the Purchaser may, at its discretion, ask any vendor for a clarification of his quotation. Any clarification submitted by a vendor in respect to his quotation which is not in response to a request by the Purchaser shall not be considered.</p> <p>14.2 The Purchaser's request for clarification and the response shall be in writing.</p> <p>14.3 Bids were submitted by Public Enterprise will be given a 15% special preference.</p>
<p>15. Responsiveness of Quotations</p>	<p>15.1 The Purchaser will determine the responsiveness of the quotation to the documents based on the contents of the quotation received.</p> <p>15.2 If a quotation is evaluated as not substantially responsive to the documents issued, it may be rejected by the Purchaser.</p>
<p>16. Evaluation of quotations</p>	<p>16.1 The Purchaser shall evaluate each quotation that has been determined, to be substantially responsive.</p> <p>16.2 To evaluate a quotation, the Purchaser may consider the following:</p> <ul style="list-style-type: none"> (a) the Price as quoted; (b) price adjustment for correction of arithmetical errors; (c) price adjustment due to discounts offered. <p>16.3 The Purchaser's evaluation of a quotation may require the Consideration of the factors, in addition to the Price quoted if stated in Section II, Data Sheet. These factors may be related to the characteristics, performance, and terms and conditions of purchase of the Goods.</p>
<p>17. Purchaser's Right to Accept any Quotation, and to Reject any or all Quotations</p>	<p>17.1 The Purchaser reserves the right to accept or reject any quotation, and to annul the process and reject all quotations at any time prior to acceptance, without there by incurring any liability to bidders.</p>

F: Award of Contract

18. Acceptance of the Quotation	18.1 The Purchaser will accept the quotation of the vendor whose offer has been determined to be the lowest evaluated bid and is substantially responsive to the documents issued.
19. Notification of acceptance	19.1 Prior to the expiration of the period of validity of quotation, the Purchaser will notify the successful vendor, in writing, that his quotation has been accepted.

Section II: Data Sheet

ITV Clause Reference	
1.1	The Purchaser is: Vice Chancellor Address: University of Ruhuna, Wellamadama Matara.
5.1	If the bidder is not allowed to quote for lesser number of items than the total number of items specified, indicate the details.
7.3	Manufacturer's Authorization is required.
11.1	Address for submission of Quotations is Supplies Branch, University of Ruhuna, Wellamadama, Matara. Deadline for submission of Quotations is at 2.00p.m. on 12.09.2024
13	The Quotations shall be opened at the following address: Supplies Branch, University of Ruhuna, Wellamadama, Matara.
16	Other factors that will be considered for evaluation are (Bidder should quote all item listed in the price schedule and evaluation will be done total cost)
Additional Clause	
17. Payment	Payment shall be made within four weeks after receiving the invoice for each item supplied.
18. Liquidated Damages	The supplier should deliver the items within the delivery period stipulated in the schedule of requirements. The supplier should make payment to the purchaser for each week of delay in delivery, at the rate of 0.5% of the contract sum per each week of delay, up to a maximum of 10% of the contract sum.

Section III: Schedule of Requirements

Item Number	Brief Description of the Goods	Specification and Requirements	Qty	Delivery Period in Days from issue of Purchase Order	Place of Delivery	Installation and warranty Requirements if any
01	Steel Filling Cabinet	Specification Attached (Annex 01)	02	02 weeks	University of Ruhuna, Wellamadama, Matara	Warranty Required
02	Wooden Cupboard with Glass Doors	Specification Attached (Annex 02)	04	02 weeks	University of Ruhuna, Wellamadama, Matara	Warranty Required
03	Low Back Chair	Specification Attached (Annex 03)	02	02 weeks	University of Ruhuna, Wellamadama, Matara	Warranty Required
04	Computer Chair	Specification Attached (Annex 04)	06	02 weeks	University of Ruhuna, Wellamadama, Matara	Warranty Required
05	Office Table	Specification Attached (Annex 05)	03	02 weeks	University of Ruhuna, Wellamadama, Matara	Warranty Required
06	Computer Table	Specification Attached (Annex 06)	04	02 weeks	University of Ruhuna, Wellamadama, Matara	Warranty Required
07	Steel Single Bed	Specification Attached (Annex 07)	20	02 weeks	University of Ruhuna, Wellamadama, Matara	Warranty Required

Please mention your delivery period -

If you not mentioned the delivery period, earliest delivery period 02 weeks is accepted.

.....
Signature

.....
Date

.....
Rubber Stamp

Section V

Quotation Submission Form

[The Vendor shall fill in this Form in accordance with the instructions indicated. No Alterations to its form at shall be permitted and no substitutions will be accepted.]

Date:

To: Vice Chancellor, University of Ruhuna

We, the undersigned, declare that:

- (a) We have examined and have no reservations to the document issued;
- (b) We offer to supply in conformity with the documents issued and in accordance with the Delivery Schedules specified in the Schedule of Requirements, the following Goods[Supply, Delivery, Installation, Commissioning and Testing of Air Conditioners in the different places for the university of Ruhuna, Wellamadama, Matara as per schedule of requirement];
- (c) The total price of our quotation including any discounts offered is Rupees..... (LKR) excluding VAT
- (d) Our quotation shall be valid for the period of time specified in ITVSub-Clause8.1, from the date fixed for the quotation submission deadline in accordance with ITV Sub-Clause11.1, and it shall remain binding upon us and may be accepted at any time before the expiration of that period;
- (e) We understand that this quotation, together with your written acceptance thereof included in your notification of award, shall constitute a binding contract between us.
- (f) We understand that you are not bound to accept the lowest evaluated quotation or any other quotation that you may receive.

Signed:.....

[insert signature of Person whose name and capacity are shown]

Name:.....

[insert complete name of person signing the Bid Submission Form]

Dated:

PRICE SCHEDULE

Package Name: Supply, Delivery, Installation, Commissioning and Testing of Furniture

Item. No.	Description	Qty	Unit Rate. (Without VAT) (Rs.)	Total Amount (Without VAT) (Rs.)	VAT (Rs.)	Total Amount (With VAT) (Rs.)
01.	Steel Filling Cabinet	02				
02.	Wooden Cupboard with Glass Doors	04				
03.	Low Back Chair	02				
04.	Computer Chair	06				
05.	Office Table	03				
06.	Computer Table	04				
07.	Steel Single Bed	20				

We agree to supply, delivery, installation & maintenance the above goods in accordance with the technical specifications for a total contract price of Rupees ... (amount in figures) (amount in words) within the

period specified in the Invitation for Quotations.

We also confirm that the warrantee/guarantee specified shall apply to the offered goods.

.....

Signature of the Bidder

Name of the Bidder

Date

Specifications for Steel Filing Cabinet– 02 No.

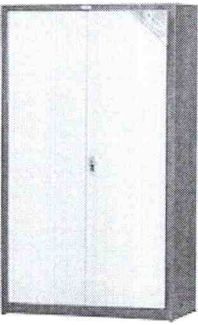
Specification/s	Requirements	Conformity		If No, Bidder's Response
		Yes	No	
Brand	Please Specify			
Model	Please Specify			
Country of Origin	Please Specify			
Number of Compartments	4 Compartments Minimum			
Material	Steel			
Powder coated finish	Required			
Dimensions				
	Length- 900mm Minimum			
	Width- 450mm Minimum			
	Height- 1800mm Minimum			
	Height of a Compartment – Please specify			
Door Locks and door handle	Required			
Other Features	Please Specify			
Warranty	2 Years Comprehensive			

Note: Please complete the all the column and rows, References to catalogues and data sheets will not be considered in the bid evaluation.

Specification for Glass Front Timber Cupboard

Required Quantity- 04 Nos.

Specification	Minimum Requirements	Conformity		If No, Bidder's Response
		Yes	No	
Make	Please Specify			
Model	Please Specify			
Cupboard dimensions (W x Lx H)	450 x 900 x 1800 mm			
Number of compartments	5			
Dimensions and Final Product	As Shown in the Drawing			
Finishing	For all surfaces one coat of wood preservative and two coat water base wood stains should be applied.			
	For outer surfaces two coats of water base polishing should be applied with Mat finish			
Material	All timber should be Teak or Jack and nails & Hinges should be brass. Door lock & handle should Stainless Steel. 5mm thick Clear Glass Should be there.			
Brochure	Brochure Attached Herewith			
Warranty (if any condition please specify)	Warranty/ Defect rectification period is three years			
Other	A sample of the Cupboard made to the given specification should be submitted for evaluation when the supplier is informed			

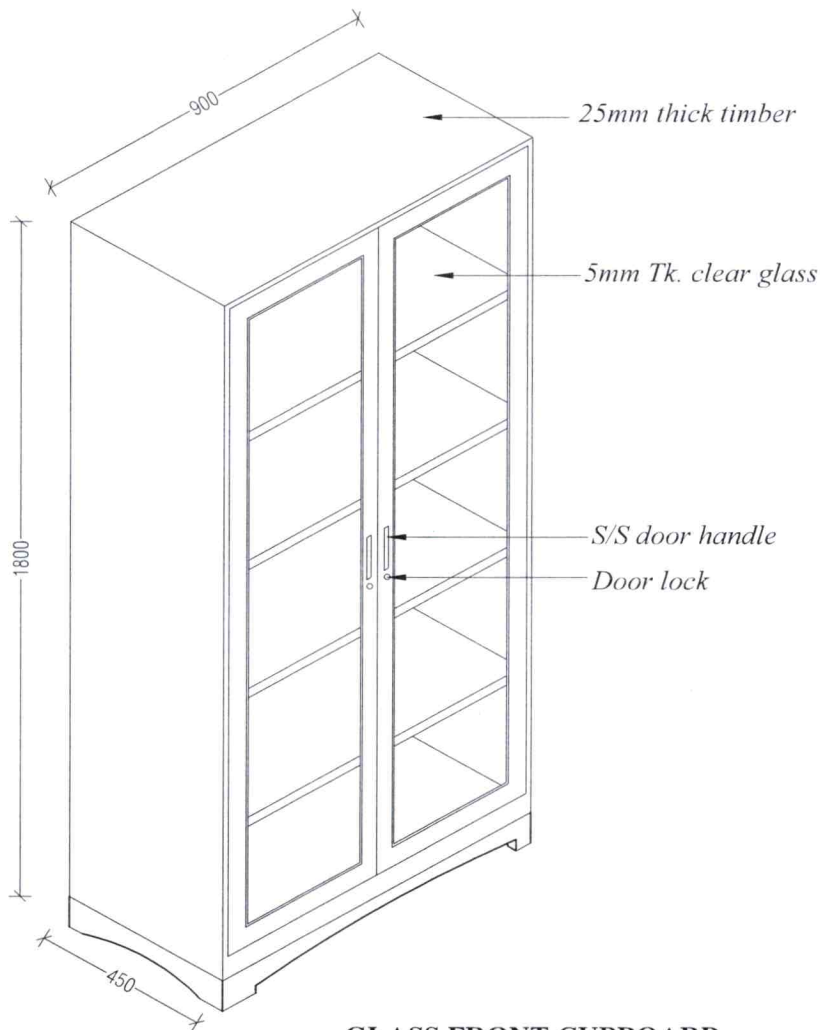

GLASS FRONT CUPBOARD

Specifications and other information for Glass Front Cupboard

01. All timber should be Teak or Jack and nails should be brass
02. For all surfaces one coat of wood preservative and two coat water base wood stains should be applied
03. For outer surfaces two coats of water base polishing should be applied with Mat finish
04. A sample of the cupboard made to the given specification should be submitted for evaluation when the supplier is informed
05. Warranty/ Defect rectification period is three years

**SPECIFICATION OF FURNITURE FOR
FACULTY OF GRADUATE STUDIES @
UNIVERSITY OF RUHUNA,
FORT, MATARA.**

Drwg No	:	
Scale	:	NTS
Date	:	
Drawn by	:	Piyumi Ariyaratna

Signature of Engineer

LANDS & BUILDING MAINTENANCE UNIT

UNIVERSITY OF RUHUNA, WELLAMADAMA, MATARA.

Specification for Low Back Chair

Required Quantity: 02

Specification	Requirements	Conformity		If No, Bidder's Response
		Yes	No	
Make	Please Specify			
Model	Please Specify			
Seat size	Min. 450 x 450 mm (Rotatable)- Please specify			
Height	Should be Adjustable- Please specify			
Seat type	High Quality Fabric Cushion as shown in the Drawing Specify the material			
Back rest size	Low back as shown in the picture. (Mini- 500x 450 mm) Please specify			
Chair legs	Five legs with wheels			
Structure	Corrosion resistant steel (Specify treatment)			
Wheel Castors	The twin wheel castors are injection molded in Black-Nylon			
Plastic structural components	Specify material			
Colour	Please specify			
Pneumatic Height Adjustment	Should have Pneumatic Height Adjustment.			
Image				
Warranty	2 years Warranty			

Note: Please complete the all the column and rows, References to catalogues and data sheets will not be considered in the bid evaluation.

Specification for Computer Chair

Required Quantity: 06

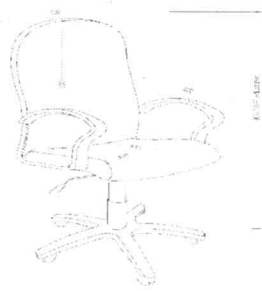
Specification	Requirements	Conformity		If No, Bidder's Response
		Yes	No	
Make	Please Specify			
Model	Please Specify			
Seat size	Min. 450 x 450 mm (Rotatable)- Please specify			
Height	Adjustable (950 to 1000 mm) - Please specify			
Seat type	High Quality Fabric Cushion as shown in the Drawing Specify the material			
Back rest size	Mid back as shown in the picture. (Mini- 500x 500 mm) Please specify			
Chair legs	Five legs with wheels			
Structure	Corrosion resistant steel (Specify treatment)			
Wheel Castors	The twin wheel castors are injection molded in Black-Nylon			
Plastic structural components	Specify material			
Colour	Please specify			
Pneumatic Height Adjustment	Should have Pneumatic Height Adjustment.			
Image				
Warranty	3 years Minimum Comprehensive warranty			

Note: Please complete the all the column and rows, References to catalogues and data sheets will not be considered in the bid evaluation.

Specification for Office Table

Required Quantity- 03 Nos.

Specification	Minimum Requirements	Conformity		If No, Bidder's Response
		Yes	No	
Make	Please Specify			
Model	Please Specify			
Table top size	Main Table – 1200 x 700 mm			
Number of Drawers	02 Number lockable (Heavy-duty)			
Table height	775 mm			
Dimensions and Final Product	As Shown in the Drawing			
Finishing	For all surfaces one coat of wood preservative and two coat water base wood stains should be applied.			
	For outer surfaces two coats of water base polishing should be applied with Mat finish			
Material	All timber should be Teak or Jack and nails should be brass			
Sample	Required			
Warranty	3 Years Comprehensive			

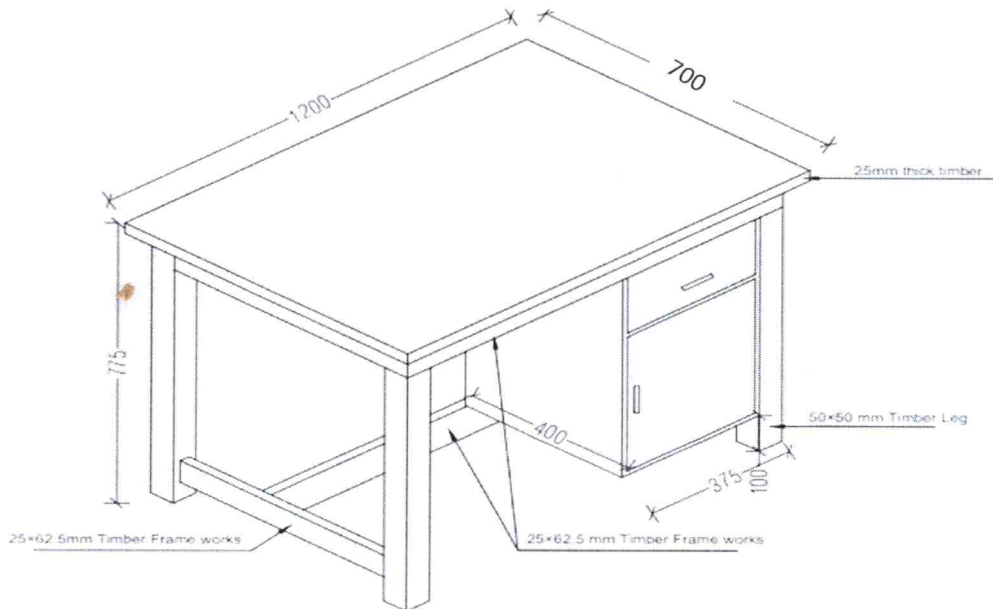

Specification for Computer Table

Required Quantity: 04

Specification	Requirements	Conformity		If No, Bidder's Response
		Yes	No	
Make	Please Specify			
Model	Please Specify			
Size	800mm (L), 400mm (W), 750mm(H)- Please Specify			
Material	Laminated Melamine Board (Minimum Thickness 18mm)			
Wheels	4 Numbers - The twin wheel castors are injection molded in Black			
Colour	Please specify			
Image				
Sample	Required			
Warranty	3 years Minimum Comprehensive warranty			

Note: Please complete the all the column and rows, References to catalogues and data sheets will not be considered in the bid evaluation.

Specification for Steel Single Bed

Required Quantity- 20 Nos.

Specification	Minimum Requirements	Conformity		If No, Bidder's Response
		Yes	No	
Make	Please Specify			
Model	Please Specify			
Bed dimensions	As per the attached drawing			
Material	All steel GI pipes should be heavy gauge with a minimum thickness of 2.3 mm.			
	15mm thick approved quality Eco board on which mattress to be placed			
Material Sample	GI pipe Samples and Eco board samples should be submitted before fabrication for approval			
Painting	All steel should be painted with two coats of anti-corrosive primer and two coats of enamel paint (Black)			
Welded Joints	All welded joints should be neatly grinded and finished			
Samples	Single bed sample should be submitted for evaluation when the supplier is informed			
Warranty	Warranty /Defect rectification period is one year			
Supply, Fixing and Delivery	All Single beds should be delivered to the specified Hostels and installed			

SPECIFICATION FOR STEEL SINGLE BED

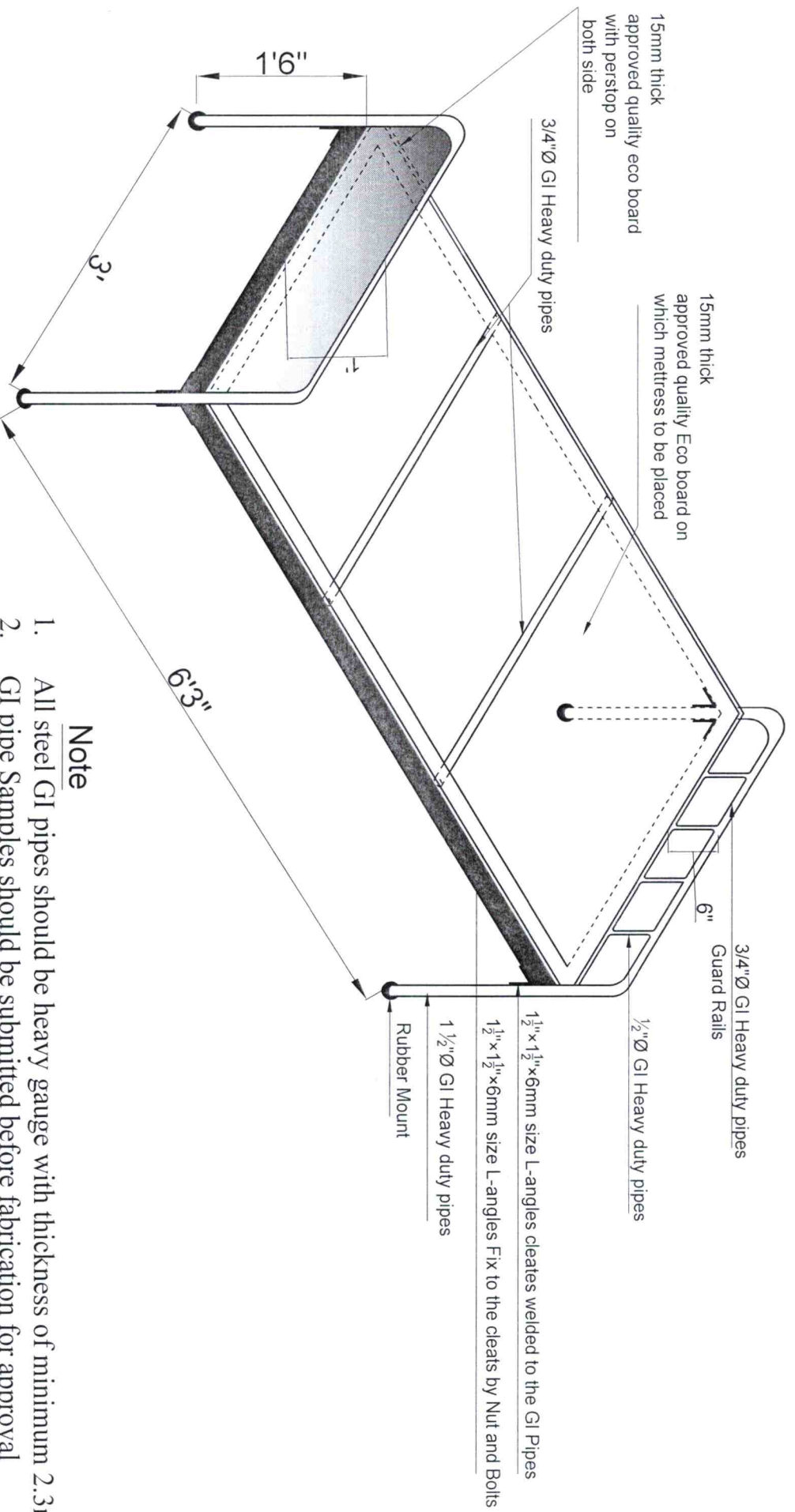

Note

1. All steel GI pipes should be heavy gauge with thickness of minimum 2.3mm
2. GI pipe Samples should be submitted before fabrication for approval
3. All steel should be painted with two coats of anti corrosive primer and two coats of enamel paint (Black)
4. All welded joints should be neatly grinded and finished
5. Single bed sample should be submitted for evaluation when the supplier is informed
6. All Single beds should be delivered to the specified Hostels and installed
7. Warranty /Defect rectification period is one year

Steel Single Bed