

DEMOCRATIC SOCIALIST REPUBLIC OF SRI LANKA
MINISTRY OF EDUCATION



UNIVERSITY OF RUHUNA

ADDENDUM 1

**Supply, Delivery, Installation, Commissioning, Testing and Maintenance of
Laboratory Equipment, Plant & Machinery, Computer
Software/Hardware & Accessories, Office Equipment & Furniture &
Others for University of Ruhuna**

RUH/SUP/MENA/NCB/2023/01

**Package No. 10: Supply, Delivery, Installation, Commissioning, Testing and
Maintenance of Laboratory and Lecture Room Furniture for DMENA, Faculty of
Engineering, University of Ruhuna.**

This Amendment shall be considered part of the bid documents for the Supply, Delivery, Installation, Commissioning, Testing and Maintenance of Laboratory Equipment, Plant & Machinery, Computer Software/Hardware & Accessories, Office Equipment & Furniture & Others for the DMENA, Faculty of Engineering, University of Ruhuna and shall be incorporated integrally therewith. Where provisions of the following supplementary data differ from those of the original bid documents, this Amendment shall govern and take precedence. BIDDERS MUST SIGN THE AMENDMENT AND SUBMIT IT WITH THEIR BIDS.

Except as described below, the original bid document remains unchanged. The bid documents are modified and/or clarified, as follows;

Section II

Bidding Data Sheet (BDS)

The date in ITB 19.1, 20.2, 23.1 & ITB 26.1 has been changed as follows and other details remains unchanged.

ITB Clause Reference	A. General																																																																				
ITB 19.1	The bid shall be validity until: 90 days from the bid opening date																																																																				
ITB 20.2	<p>The amount of the Bid Security shall be as follows:</p> <p><u>Package No. 10: Supply, Delivery, Commissioning, Testing and Maintenance of Laboratory and Lecture Room Furniture</u></p> <table border="1" style="width: 100%; border-collapse: collapse;"> <thead> <tr> <th style="text-align: center;">Item No</th> <th style="text-align: center;">Goods/Descriptions</th> <th style="text-align: center;">Qty</th> <th style="text-align: center;">Bid Security (Rs.)</th> </tr> </thead> <tbody> <tr> <td style="text-align: center;">10.1</td> <td>Lab Study Table</td> <td style="text-align: center;">09</td> <td style="text-align: right;">10,000.00</td> </tr> <tr> <td style="text-align: center;">10.2</td> <td>Lab Study Table Stools</td> <td style="text-align: center;">108</td> <td style="text-align: right;">11,000.00</td> </tr> <tr> <td style="text-align: center;">10.3</td> <td>Tool Tables for Machines</td> <td style="text-align: center;">05</td> <td style="text-align: right;">3,000.00</td> </tr> <tr> <td style="text-align: center;">10.4</td> <td>TO Office Tables</td> <td style="text-align: center;">06</td> <td style="text-align: right;">3,000.00</td> </tr> <tr> <td style="text-align: center;">10.5</td> <td>Changing Room locker</td> <td style="text-align: center;">02</td> <td style="text-align: right;">1,000.00</td> </tr> <tr> <td style="text-align: center;">10.6</td> <td>Steel Cupboards</td> <td style="text-align: center;">22</td> <td style="text-align: right;">12,000.00</td> </tr> <tr> <td style="text-align: center;">10.7</td> <td>Wooden Cupboards</td> <td style="text-align: center;">08</td> <td style="text-align: right;">3,000.00</td> </tr> <tr> <td style="text-align: center;">10.8</td> <td>Lecture Room Tables</td> <td style="text-align: center;">03</td> <td style="text-align: right;">1,000.00</td> </tr> <tr> <td style="text-align: center;">10.9</td> <td>Lecturer Office Tables</td> <td style="text-align: center;">13</td> <td style="text-align: right;">11,000.00</td> </tr> <tr> <td style="text-align: center;">10.10</td> <td>Executive Chairs</td> <td style="text-align: center;">10</td> <td style="text-align: right;">5,000.00</td> </tr> <tr> <td style="text-align: center;">10.11</td> <td>Book rack</td> <td style="text-align: center;">20</td> <td style="text-align: right;">4,000.00</td> </tr> <tr> <td style="text-align: center;">10.12</td> <td>Lecture Room Study Tables</td> <td style="text-align: center;">150</td> <td style="text-align: right;">30,000.00</td> </tr> <tr> <td style="text-align: center;">10.13</td> <td>Canteen/ Study Area Tables</td> <td style="text-align: center;">18</td> <td style="text-align: right;">8,000.00</td> </tr> <tr> <td style="text-align: center;">10.14</td> <td>Canteen Chairs</td> <td style="text-align: center;">100</td> <td style="text-align: right;">5,000.00</td> </tr> <tr> <td style="text-align: center;">10.15</td> <td>Wooden Platforms for Lecture Room (16 ft x 6 ft x 0.5 ft)</td> <td style="text-align: center;">03</td> <td style="text-align: right;">5,000.00</td> </tr> <tr> <td style="text-align: center;">10.16</td> <td>Pigeon hole rack</td> <td style="text-align: center;">01</td> <td style="text-align: right;">1,000.00</td> </tr> </tbody> </table> <p>Beneficiary: Vice Chancellor, University of Ruhuna The validity period of the Bid Security shall be until: 30 days beyond the date of bid validity period.</p>	Item No	Goods/Descriptions	Qty	Bid Security (Rs.)	10.1	Lab Study Table	09	10,000.00	10.2	Lab Study Table Stools	108	11,000.00	10.3	Tool Tables for Machines	05	3,000.00	10.4	TO Office Tables	06	3,000.00	10.5	Changing Room locker	02	1,000.00	10.6	Steel Cupboards	22	12,000.00	10.7	Wooden Cupboards	08	3,000.00	10.8	Lecture Room Tables	03	1,000.00	10.9	Lecturer Office Tables	13	11,000.00	10.10	Executive Chairs	10	5,000.00	10.11	Book rack	20	4,000.00	10.12	Lecture Room Study Tables	150	30,000.00	10.13	Canteen/ Study Area Tables	18	8,000.00	10.14	Canteen Chairs	100	5,000.00	10.15	Wooden Platforms for Lecture Room (16 ft x 6 ft x 0.5 ft)	03	5,000.00	10.16	Pigeon hole rack	01	1,000.00
Item No	Goods/Descriptions	Qty	Bid Security (Rs.)																																																																		
10.1	Lab Study Table	09	10,000.00																																																																		
10.2	Lab Study Table Stools	108	11,000.00																																																																		
10.3	Tool Tables for Machines	05	3,000.00																																																																		
10.4	TO Office Tables	06	3,000.00																																																																		
10.5	Changing Room locker	02	1,000.00																																																																		
10.6	Steel Cupboards	22	12,000.00																																																																		
10.7	Wooden Cupboards	08	3,000.00																																																																		
10.8	Lecture Room Tables	03	1,000.00																																																																		
10.9	Lecturer Office Tables	13	11,000.00																																																																		
10.10	Executive Chairs	10	5,000.00																																																																		
10.11	Book rack	20	4,000.00																																																																		
10.12	Lecture Room Study Tables	150	30,000.00																																																																		
10.13	Canteen/ Study Area Tables	18	8,000.00																																																																		
10.14	Canteen Chairs	100	5,000.00																																																																		
10.15	Wooden Platforms for Lecture Room (16 ft x 6 ft x 0.5 ft)	03	5,000.00																																																																		
10.16	Pigeon hole rack	01	1,000.00																																																																		
ITB 23.1	<p>For bid submission purposes, the Purchaser's address is:</p> <p style="text-align: center;">Attention: The Chairman, Ministry Procurement Committee, Ministry of Education, Higher Education Division, No 18, Ward Place, Colombo 07</p> <p>Tender Box – Director, Infrastructure Development Office</p> <p>The deadline for the submission of bids is: Date: 29.08.2023 Time: 11.00 hours</p>																																																																				

ITB 26.1	<p>The bid opening shall take place at:</p> <p>Address: The Chairman, Ministry Procurement Committee, Ministry of Education, Higher Education Division, No 18, Ward Place, Colombo 07</p> <p>Tender Box – Director, Infrastructure Development Office</p> <p>Date: 29.08.2023</p> <p>Time: 11.00 hours</p>
----------	--

Section V

Schedule of Requirements

1. List of Goods and Delivery Schedule

[The Purchaser shall fill in this table, with the exception of the column "Bidder's offered Delivery date" to be filled by the Bidder]

Bidding Item No.	Description of Goods	Qty.	Final Destination as specified in BDS	Delivery Date		
				Earliest Delivery Date	Latest Delivery Date	Bidder's offered Delivery Date
10.1	Lab Study Table	09	Faculty of Engineering, Hapugala, Galle	2 weeks	8 weeks	
10.2	Lab Study Table Stools	108	Faculty of Engineering, Hapugala, Galle	2 weeks	8 weeks	
10.3	Tool Tables for Machines	05	Faculty of Engineering, Hapugala, Galle	2 weeks	8 weeks	
10.4	TO Office Tables	06	Faculty of Engineering, Hapugala, Galle	2 weeks	8 weeks	
10.5	Changing Room locker	02	Faculty of Engineering, Hapugala, Galle	2 weeks	8 weeks	
10.6	Steel Cupboards	22	Faculty of Engineering, Hapugala, Galle	2 weeks	8 weeks	
10.7	Wooden Cupboards	08	Faculty of Engineering, Hapugala, Galle	2 weeks	8 weeks	
10.8	Lecture Room Tables	03	Faculty of Engineering, Hapugala, Galle	2 weeks	8 weeks	
10.9	Lecturer Office Tables	13	Faculty of Engineering, Hapugala, Galle	2 weeks	8 weeks	
10.10	Executive Chairs	10	Faculty of Engineering, Hapugala, Galle	2 weeks	8 weeks	
10.11	Book rack	20	Faculty of Engineering, Hapugala, Galle	2 weeks	8 weeks	
10.12	Lecture Room Study Tables	150	Faculty of Engineering, Hapugala, Galle	2 weeks	8 weeks	
10.13	Canteen/ Study Area Tables	18	Faculty of Engineering, Hapugala, Galle	2 weeks	8 weeks	
10.14	Canteen Chairs	100	Faculty of Engineering, Hapugala, Galle	2 weeks	8 weeks	
10.15	Wooden Platforms for Lecture Room (16 ft x 6 ft x 0.5 ft)	03	Faculty of Engineering, Hapugala, Galle	2 weeks	8 weeks	

10.16	Pigeon hole rack	01	Faculty of Engineering, Hapugala, Galle	2 weeks	8 weeks	
-------	------------------	----	--	---------	---------	--

.....
Signature of the bidder with official rubber stamp

.....
Date

2. Technical Specifications and Bidder's Response

(No alternative design shall be considered. The bidder shall follow the technical specifications given in relevant drawings and other requirements given in the bidding document.)

2.1 Technical Specifications

RUH/SUP/MENA/NCB/2023/01

Item No	Goods/Descriptions	Specification
10.1	Lab Study Table	Appendix 10.1
10.2	Lab Study Table Stools	Appendix 10.2
10.3	Tool Tables for Machines	Appendix 10.3
10.4	TO Office Tables	Appendix 10.4
10.5	Changing Room locker	Appendix 10.5
10.6	Steel Cupboards	Appendix 10.6
10.7	Wooden Cupboards	Appendix 10.7
10.8	Lecture Room Tables	Appendix 10.8
10.9	Lecturer Office Tables	Appendix 10.9
10.10	Executive Chairs	Appendix 10.10
10.11	Book rack	Appendix 10.11
10.12	Lecture Room Study Tables	Appendix 10.12
10.13	Canteen/ Study Area Tables	Appendix 10.13
10.14	Canteen Chairs	Appendix 10.14
10.15	Wooden Platforms for Lecture Room (16 ft x 6 ft x 0.5 ft)	Appendix 10.15
10.16	Pigeon hole rack	Appendix 10.16

2.2 Bidder's Response

RUH/SUP/MENA/NCB/2023/01

Item No	Description of Goods	Qty	Specifications	Bidder's Response		Remarks
				Yes	No	
10.1	Lab Study Table	09	Appendix 10.1			
10.2	Lab Study Table Stools	108	Appendix 10.2			
10.3	Tool Tables for Machines	05	Appendix 10.3			
10.4	TO Office Tables	06	Appendix 10.4			
10.5	Changing Room locker	02	Appendix 10.5			
10.6	Steel Cupboards	22	Appendix 10.6			
10.7	Wooden Cupboards	08	Appendix 10.7			
10.8	Lecture Room Tables	03	Appendix 10.8			
10.9	Lecturer Office Tables	13	Appendix 10.9			
10.10	Executive Chairs	10	Appendix 10.10			
10.11	Book rack	20	Appendix 10.11			
10.12	Lecture Room Study Tables	150	Appendix 10.12			
10.13	Canteen/ Study Area Tables	18	Appendix 10.13			
10.14	Canteen Chairs	100	Appendix 10.14			
10.15	Wooden Platforms for Lecture Room (16 ft x 6 ft x 0.5 ft)	03	Appendix 10.15			
10.16	Pigeon hole rack	01	Appendix 10.16			

Appendix 10.1

Specification: **Laboratory Table - 09 Nos**

Item No.	Specification	Requirements	Conformity		If No, Bidder's Response
			Yes	No	
1	Table top size (W x L)	7'-0" x 4'-0"			
2	Table height (H)	3'-0"			
3	Drawers and Cupboard	No			
4	Finishing	Finishing thickness of furniture must be exactly equal or better to the size indicated in the image, and will be rejected if any deviations found			
		All nails and screws should be brass			
		All stains and finishes applied shall be water base and of the highest quality available in the industry. eg. JAT. TEC prior approval is required if finishes other than JAT products are used as wood preservatives stains and surfaces finishes.			
		Timber used shall be applied with wood preservatives before and after making of furniture and after Inspected by the TEC three coats of Stain teak and two layers mat surface protection layers shall be applied. After application of each stain furniture shall be applied sand paper 80,120,320 or otherwise as recommended by the manufacture of the surface coatings. Eg. JAT products.			
5	Material	Timber species - Solid teak wood, sustainably harvested from more than 30 years old forest plantations. Supplier shall furnished all the government permits for felling and transporting of the logs that goes into the making of the furniture.			
		Teak timber must be well seasoned & treated of which, moisture level must be less than 12%. Certificate for treatment /receipt of treatment of the logs for the above moisture level used for the fabrication of the furniture shall be provided by the supplier.			
		Usage of SAP wood must be less than 10%. To ensure this condition the products should be presented to the University appointed Technical Evaluation Committee for their approval before the application of stains and application any other surface protection and appearance enhancement agents. Only those samples that were provisionally approved will be finally checked and accepted against the sample for payments.			

6	Other specification	Please specify.			
7	Warranty (if any condition please specify)	Minimum warranty period must be 5 years			
10	Other	Supplier should agree that the placement of purchase order is subjected to submission of the sample within 7 days after the request and attending to any defects correction of the sample within 7 days from the submission of the sample. Note. University reserve the right to reject the samples that do not comply with the above deadlines and collect sample and award the contract to the next recommended bidder by the TEC (Technical Evaluation Committee).			
		All final purchases shall confirm to the quality and workmanship of the sample submitted and checked and approved before the placement of the order.			
		Bidders must have more than 5 years experience in wood industry (Proof documents must be attached)			
		Proof Documents with contact details as attached for 5 years' experience of supplying similar furniture items			

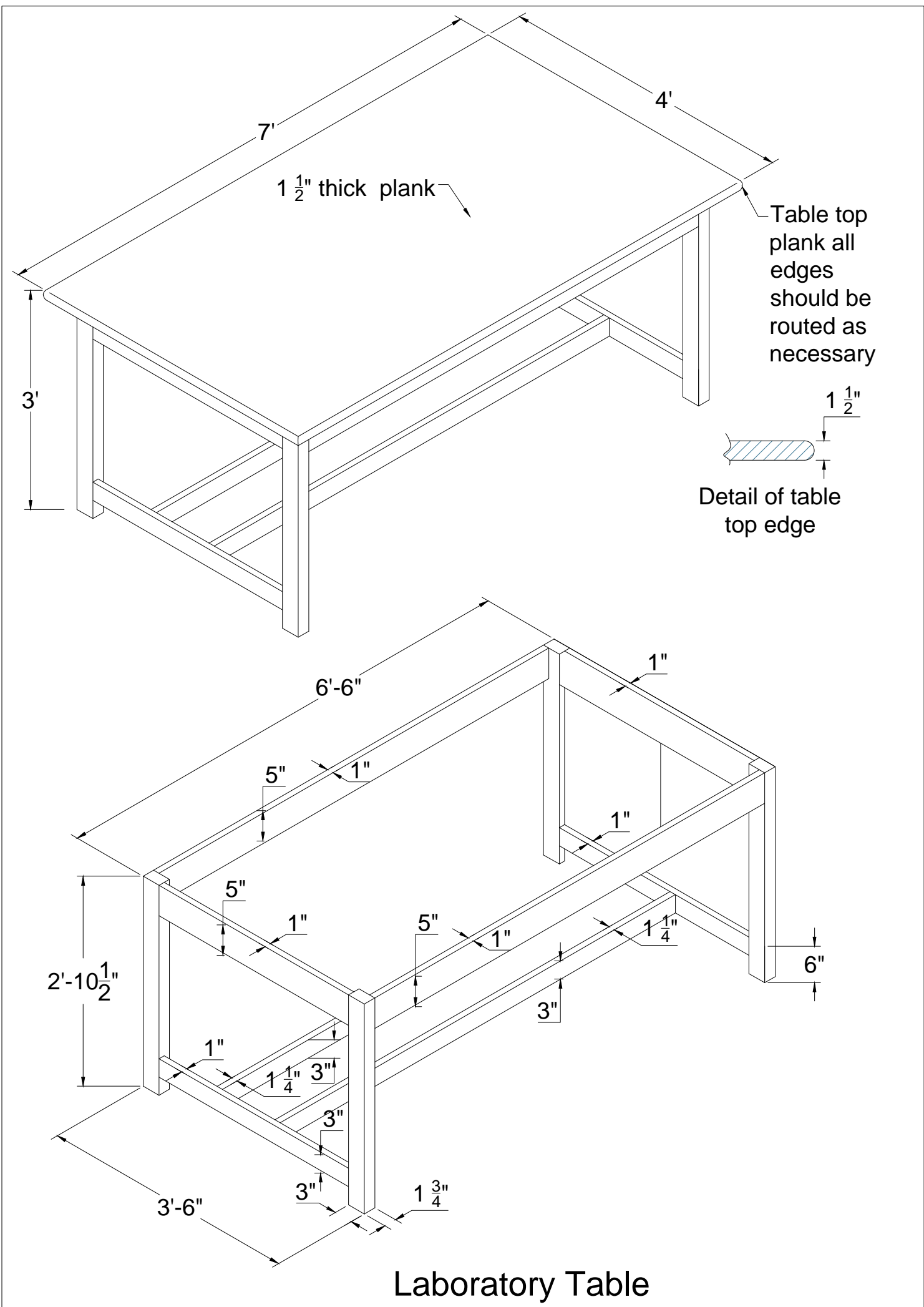

Appendix 10.2

Specification: Lab Study Table Stools -108 Nos

Item No.	Specification	Requirements	Conformity		If No, Bidder's Response
			Yes	No	
1	Stool seat size (W x L)	13 ½" x 13 ½"			
2	Stool height (H)	27"			
3	Finishing	Finishing thickness of furniture must be exactly equal or better to the size indicated in the image, and will be rejected if any deviations found			
		All nails and screws should be brass			
		All stains and finishes applied shall be water base and of the highest quality available in the industry (eg.. JAT). TEC prior approval is required if finishes other than JAT products are used as wood preservatives stains and surfaces finishes.			
		Timber used shall be applied with wood preservatives before and after making of furniture and after Inspected by the TEC three coats of Stain teak and two layers mat surface protection layers shall be applied. After application of each stain furniture shall be applied sand paper 80,120,320 or otherwise as recommended by the manufacture of the surface coatings (eg. JAT products).			
4	Material	Timber species - Solid teak wood, sustainably harvested from more than 30 years old forest plantations. Supplier shall furnished all the government permits for felling and transporting of the logs that goes into the making of the furniture.			
		Teak timber must be well seasoned & treated of which, moisture level must be less than 12%. Certificate for treatment /receipt of treatment of the logs for the above moisture level used for the fabrication of the furniture shall be provided by the supplier.			
		Usage of SAP wood must be less than 10%. To ensure this condition the products should be presented to the University appointed Technical Evaluation Committee for their approval before the application of stains and application any other surface protection and appearance enhancement agents. Only those samples that were provisionally approved will be finally checked and accepted against the sample for payments.			
5	Other specification	Please specify.			
6	Warranty (if any condition please specify)	Minimum warranty period must be 5 years			

7	Other	Supplier should agree that the placement of purchase order is subjected to submission of the sample within 7 days after the request and attending to any defects correction of the sample within 7 days from the submission of the sample. Note. University reserve the right to reject the samples that do not comply with the above deadlines and collect sample and award the contract to the next recommended bidder by the TEC (Technical Evaluation Committee).			
		All final purchases shall confirm to the quality and workmanship of the sample submitted and checked and approved before the placement of the order.			
		Bidders must have more than 5 years' experience in wood industry (Proof documents must be attached)			
		Proof Documents with contact details as attached for 5 years' experience of supplying similar furniture items			

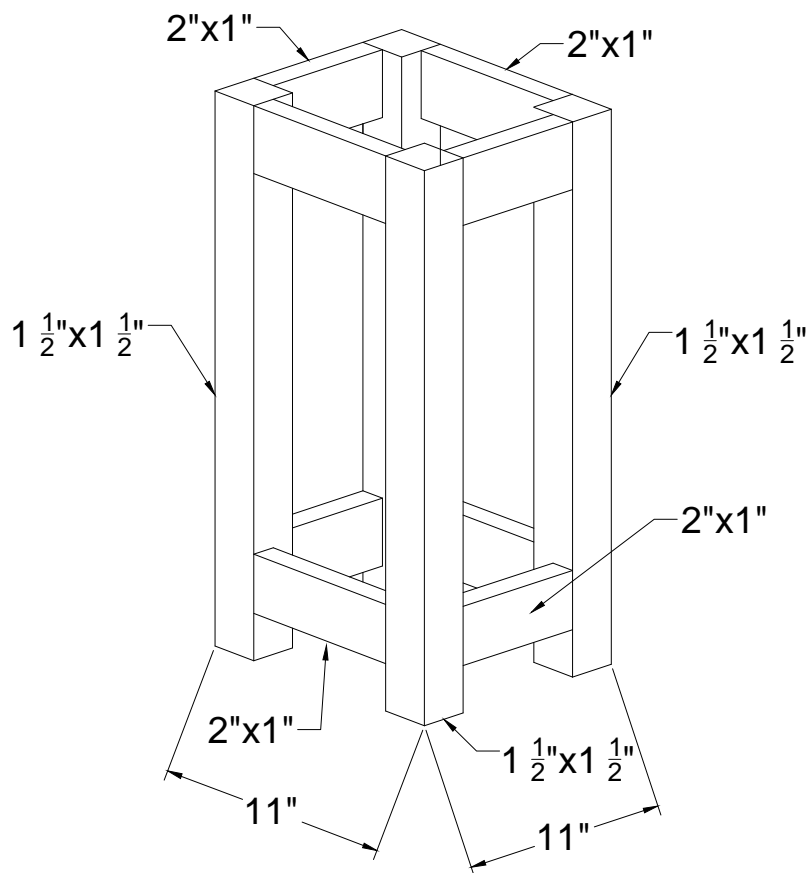
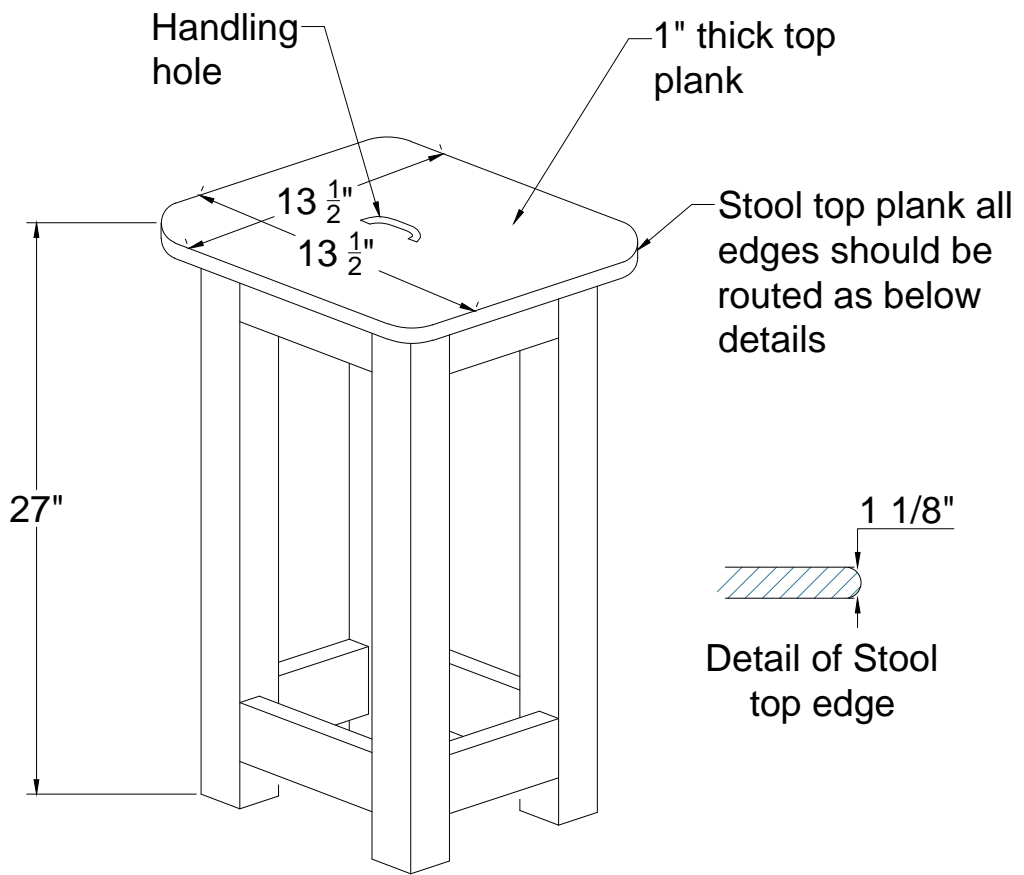

Wooden Stool For Laboratory

Appendix 10.3

Specification: Tool Tables for Machines (Workshop Trolley) - 05 Nos

Item No.	Specification	Requirements	Conformity		If No, Bidder's Response
			Yes	No	
1	Cupboard size (W x L)	18" x 24"			
2	Table height (H)	36"			
3	Shelves and cupboard	As shown in the drawing. Cupboard should be lockable with brass lock door			
4	Sheet material thickness	As shown in the drawing			
5	Finishing	As shown in the drawing.			
6	Colour	Grey			
7	Other specification	Please specify.			
8	Warranty (if any condition please specify)	Minimum warranty period must be 5 years			
9	Other	Supplier should agree that the placement of purchase order is subjected to submission of the sample within 7 days after the request and attending to any defects correction of the sample within 7 days from the submission of the sample. Note. University reserve the right to reject the samples that do not comply with the above deadlines and collect sample and award the contract to the next recommended bidder by the TEC (Technical Evaluation Committee).			
		All final purchases shall confirm to the quality and workmanship of the sample submitted and checked and approved before the placement of the order.			
		Bidders must have more than 5 years experience in relevant industry (Proof documents must be attached)			
		Proof Documents with contact details as attached for 5 years experience of supplying similar furniture items			

Appendix 10.4

Specification: **Technical Staff Table (TO Office Tables) - 06 Nos**

Item No.	Specification	Requirements	Conformity		If No, Bidder's Response
			Yes	No	
1	Table top size (W x L)	5'-0" x 3'-0"			
2	Table height (H)	2'-6"			
3	Drawers and Cupboard	Three drawers (One lockable) and Lockable cupboard with brass locks			
4	Finishing	Finishing thickness of furniture must be exactly equal or better to the size indicated in the image, and will be rejected if any deviations found			
		All nails and screws should be brass			
		All stains and finishes applied shall be water base and of the highest quality available in the industry. eg. JAT. TEC prior approval is required if finishes other than JAT products are used as wood preservatives stains and surfaces finishes.			
		Timber used shall be applied with wood preservatives before and after making of furniture and after Inspected by the TEC three coats of Stain teak and two layers mat surface protection layers shall be applied. After application of each stain furniture shall be applied sand paper 80,120,320 or otherwise as recommended by the manufacture of the surface coatings. Eg. JAT products.			
5	Material	Timber species - Solid teak wood, sustainably harvested from more than 30 years old forest plantations. Supplier shall furnished all the government permits for felling and transporting of the logs that goes into the making of the furniture.			
		Teak timber must be well seasoned & treated of which, moisture level must be less than 12%. Certificate for treatment /receipt of treatment of the logs for the above moisture level used for the fabrication of the furniture shall be provided by the supplier.			
		Usage of SAP wood must be less than 10%. To ensure this condition the products should be presented to the University appointed Technical Evaluation Committee for their approval before the application of stains and application any other surface protection and appearance enhancement agents. Only those samples that were provisionally approved will be finally checked and accepted			

		against the sample for payments.			
6	Other specification	Please specify.			
7	Warranty (if any condition please specify)	Minimum warranty period must be 5 years			
8	Other	Supplier should agree that the placement of purchase order is subjected to submission of the sample within 7 days after the request and attending to any defects correction of the sample within 7 days from the submission of the sample. Note. University reserve the right to reject the samples that do not comply with the above deadlines and collect sample and award the contract to the next recommended bidder by the TEC (Technical Evaluation Committee).			
		All final purchases shall confirm to the quality and workmanship of the sample submitted and checked and approved before the placement of the order.			
		Bidders must have more than 5 years experience in wood industry (Proof documents must be attached)			
		Proof Documents with contact details as attached for 5 years experience of supplying similar furniture items			

Appendix 10.5

Specification: Changing Room Locker (Two Tiered with Six Units) - 02 Nos

Item No.	Specification	Requirements	Conformity		If No, Bidder's Response
			Yes	No	
1	Locker size (W x L x H)	460 mm x 1000 mm x 1925 mm			
2	Sheet material thickness	Please specify (Should be able to recommend for a corrosive environment)			
3	Finishing (paints, lock, handle...etc)	Please specify. (Should be able to recommend for a corrosive environment)			
4	Colour	Grey			
5	Other specification	Please specify.			
6	Warranty (if any condition please specify)	Minimum warranty period must be 3 years			
7	Other	Supplier should agree that the placement of purchase order is subjected to submission of the sample within 7 days after the request and attending to any defects correction of the sample within 7 days from the submission of the sample. Note. University reserve the right to reject the samples that do not comply with the above deadlines and collect sample and award the contract to the next recommended bidder by the TEC (Technical Evaluation Committee).			
		All final purchases shall confirm to the quality and workmanship of the sample submitted and checked and approved before the placement of the order.			
		Bidders must have more than 5 years experience in relevant industry (Proof documents must be attached)			
		Proof Documents with contact details as attached for 5 years experience of supplying similar furniture items			

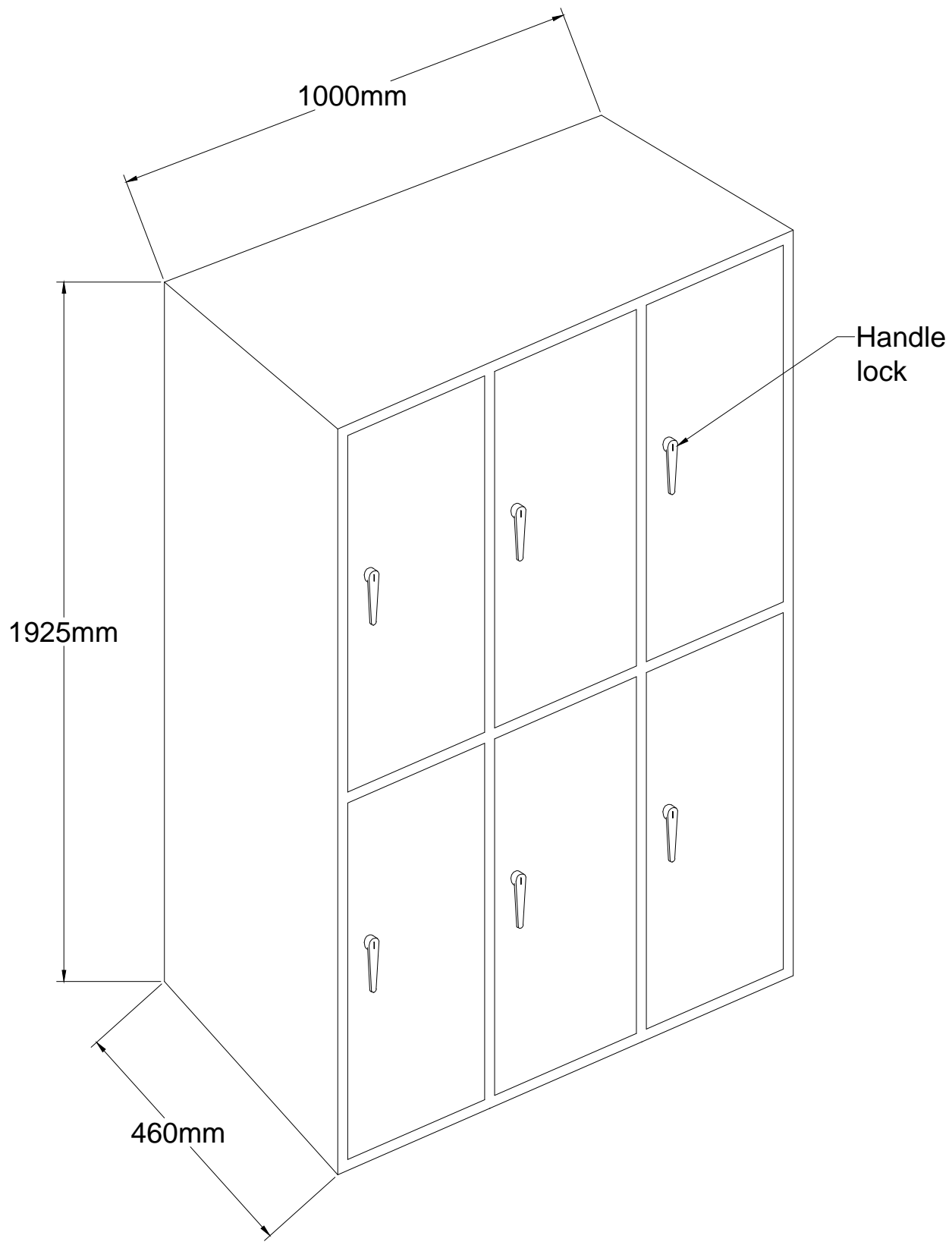

Steel Workmen Locker (6 Units)

Appendix 10.6

Specification: Steel cupboard - 22 Nos

Item No.	Specification	Requirements	Conformity		If No, Bidder's Response
			Yes	No	
1	Cupboard size (W x L)	40 cm x 80 cm			
2	Table height (H)	180 cm			
3	Shelves	As shown in the drawing			
4	Sheet material thickness	Please specify.			
5	Finishing (paints, lock, handle...etc)	Please specify.			
6	Colour	Grey			
7	Other specification	Please specify.			
8	Warranty (if any condition please specify)	Minimum warranty period must be 5 years			
9	Other	Supplier should agree that the placement of purchase order is subjected to submission of the sample within 7 days after the request and attending to any defects correction of the sample within 7 days from the submission of the sample. Note. University reserve the right to reject the samples that do not comply with the above deadlines and collect sample and award the contract to the next recommended bidder by the TEC (Technical Evaluation Committee).			
		All final purchases shall confirm to the quality and workmanship of the sample submitted and checked and approved before the placement of the order.			
		Bidders must have more than 5 years experience in relevant industry (Proof documents must be attached)			
		Proof Documents with contact details as attached for 5 years experience of supplying similar furniture items			

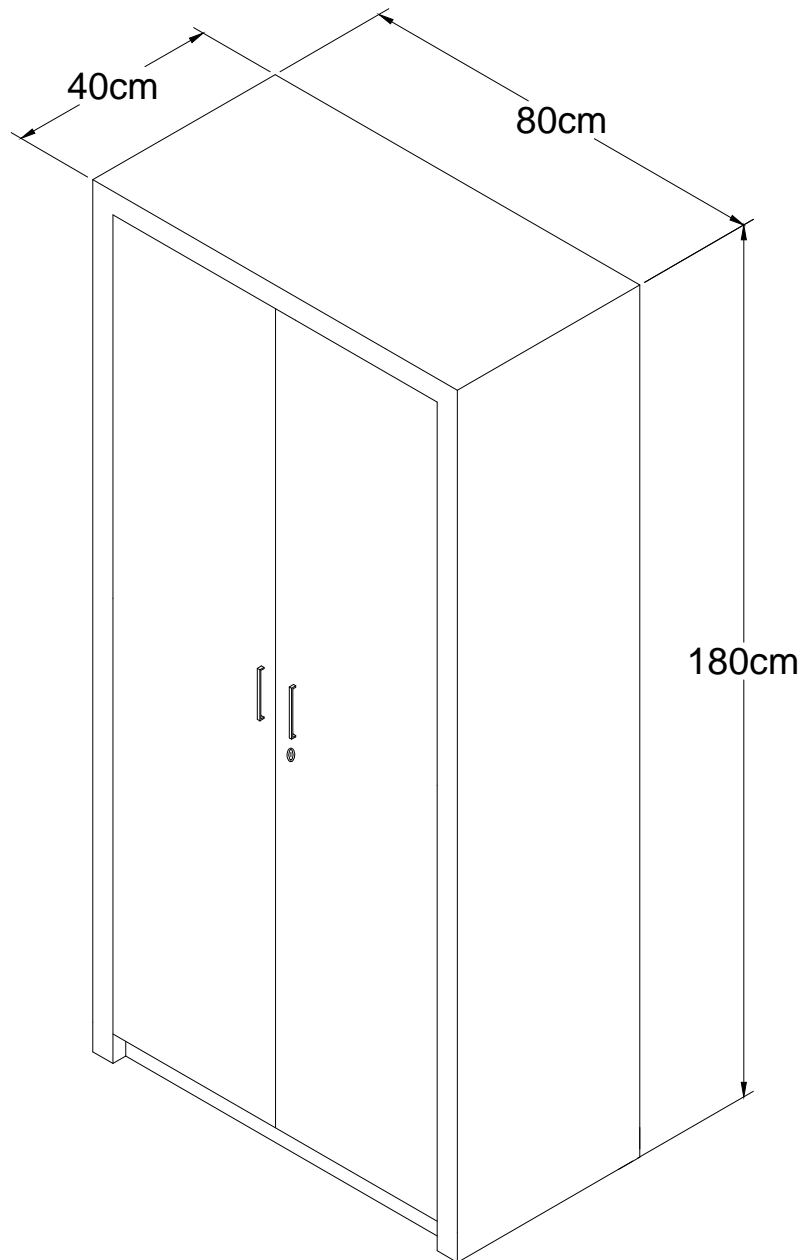

Steel Cupboard (4 racks)

Appendix 10.7

Specification: **Wooden office cupboard-08 Nos**

Item No.	Specification	Requirements	Conformity		If No, Bidder's Response
			Yes	No	
1	Cupboard size (W x L)	80cm x 40cm			
2	Cupboard height (H)	197 cm			
3	Shelves of Cupboard	As given drawing			
4	Finishing	Finishing thickness of furniture must be exactly equal or better to the size indicated in the image, and will be rejected if any deviations found			
		All nails and screws should be brass			
		All stains and finishes applied shall be water base and of the highest quality available in the industry. eg. JAT. TEC prior approval is required if finishes other than JAT products are used as wood preservatives stains and surfaces finishes.			
		Timber used shall be applied with wood preservatives before and after making of furniture and after Inspected by the TEC three coats of Stain teak and two layers mat surface protection layers shall be applied. After application of each stain furniture shall be applied sand paper 80,120,320 or otherwise as recommended by the manufacture of the surface coatings. Eg. JAT products.			
5	Material	Timber species - Solid teak wood, sustainably harvested from more than 30 years old forest plantations. Supplier shall furnished all the government permits for felling and transporting of the logs that goes into the making of the furniture.			
		Teak timber must be well seasoned & treated of which, moisture level must be less than 12%. Certificate for treatment /receipt of treatment of the logs for the above moisture level used for the fabrication of the furniture shall be provided by the supplier.			
		Usage of SAP wood must be less than 10%. To ensure this condition the products should be presented to the University appointed Technical Evaluation Committee for their approval before the application of stains and application any other surface protection and appearance enhancement agents. Only those samples that were provisionally approved will be finally checked and accepted against the sample for payments.			
6	Other	Please specify.			

	specification				
7	Warranty (if any condition please specify)	Minimum warranty period must be 5 years			
8	Other	Supplier should agree that the placement of purchase order is subjected to submission of the sample within 7 days after the request and attending to any defects correction of the sample within 7 days from the submission of the sample. Note. University reserve the right to reject the samples that do not comply with the above deadlines and collect sample and award the contract to the next recommended bidder by the TEC (Technical Evaluation Committee).			
		All final purchases shall confirm to the quality and workmanship of the sample submitted and checked and approved before the placement of the order.			
		Bidders must have more than 5 years experience in wood industry (Proof documents must be attached)			
		Proof Documents with contact details as attached for 5 years' experience of supplying similar furniture items			

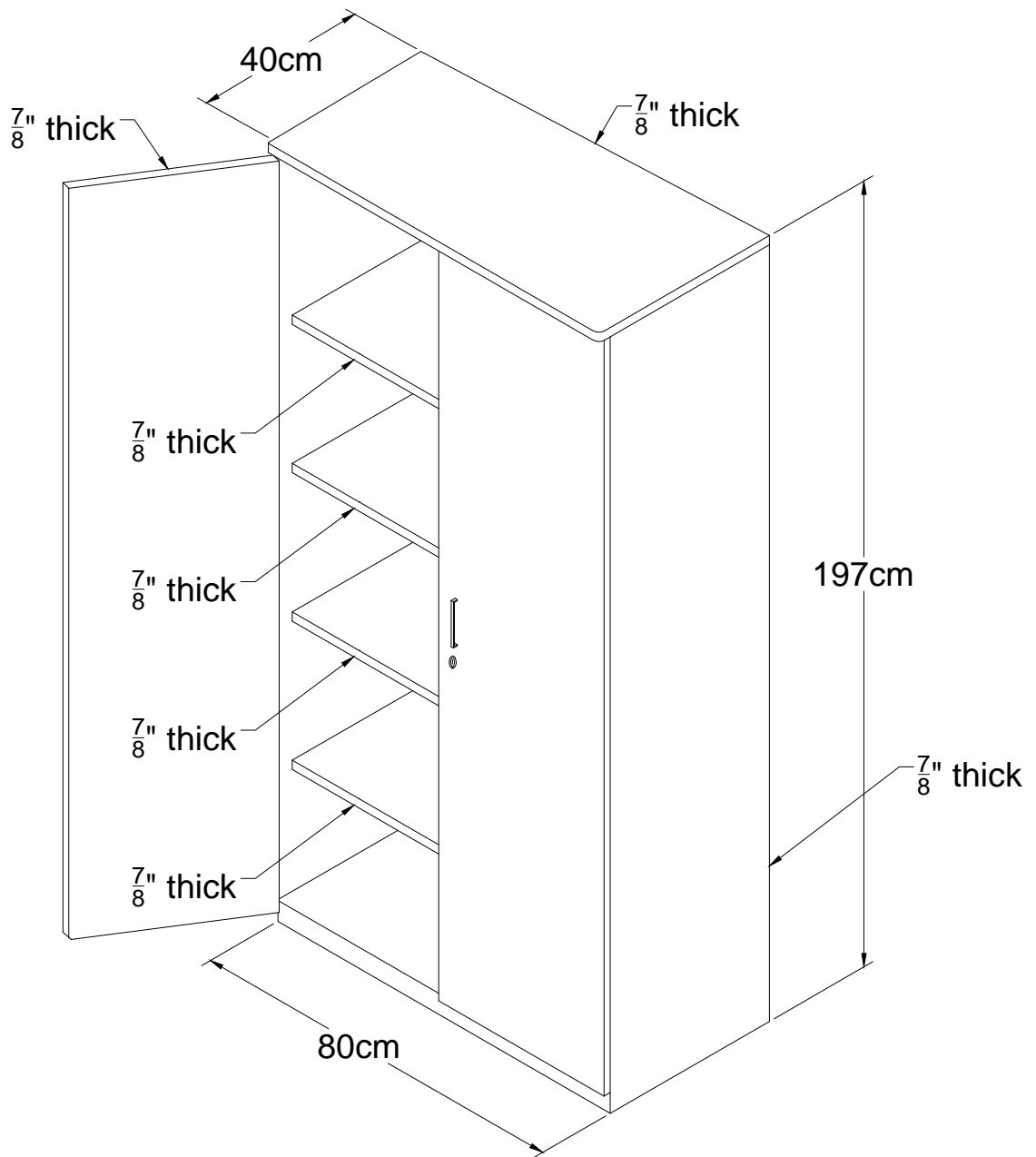

Wooden Office Cupboard

Appendix 10.8

Specification: **Wooden Lecture Room Tables - 03 Nos**

Item No.	Specification	Requirements	Conformity		If No, Bidder's Response
			Yes	No	
1	Table top size (W x L)	51" x 33"			
2	Table height (H)	30"			
3	Chambers	As shown in the drawing			
4	Finishing	Finishing thickness of furniture must be exactly equal or better to the size indicated in the image, and will be rejected if any deviations found			
		All nails and screws should be brass			
		All stains and finishes applied shall be water base and of the highest quality available in the industry. eg. JAT. TEC prior approval is required if finishes other than JAT products are used as wood preservatives stains and surfaces finishes.			
		Timber used shall be applied with wood preservatives before and after making of furniture and after Inspected by the TEC three coats of Stain teak and two layers mat surface protection layers shall be applied. After application of each stain furniture shall be applied sand paper 80,120,320 or otherwise as recommended by the manufacture of the surface coatings. Eg. JAT products.			
5	Material	Timber species - Solid teak wood, sustainably harvested from more than 30 years old forest plantations. Supplier shall furnished all the government permits for felling and transporting of the logs that goes into the making of the furniture.			
		Teak timber must be well seasoned & treated of which, moisture level must be less than 12%. Certificate for treatment /receipt of treatment of the logs for the above moisture level used for the fabrication of the furniture shall be provided by the supplier.			

		Usage of SAP wood must be less than 10%. To ensure this condition the products should be presented to the University appointed Technical Evaluation Committee for their approval before the application of stains and application any other surface protection and appearance enhancement agents. Only those samples that were provisionally approved will be finally checked and accepted against the sample for payments.			
6	Other specification	Please specify.			
7	Warranty (if any condition please specify)	Minimum warranty period must be 5 years			
8	Other	Supplier should agree that the placement of purchase order is subjected to submission of the sample within 7 days after the request and attending to any defects correction of the sample within 7 days from the submission of the sample. Note. University reserve the right to reject the samples that do not comply with the above deadlines and collect sample and award the contract to the next recommended bidder by the TEC (Technical Evaluation Committee).			
		All final purchases shall confirm to the quality and workmanship of the sample submitted and checked and approved before the placement of the order.			
		Bidders must have more than 5 years experience in wood industry (Proof documents must be attached)			
		Proof Documents with contact details as attached for 5 years experience of supplying similar furniture items.			

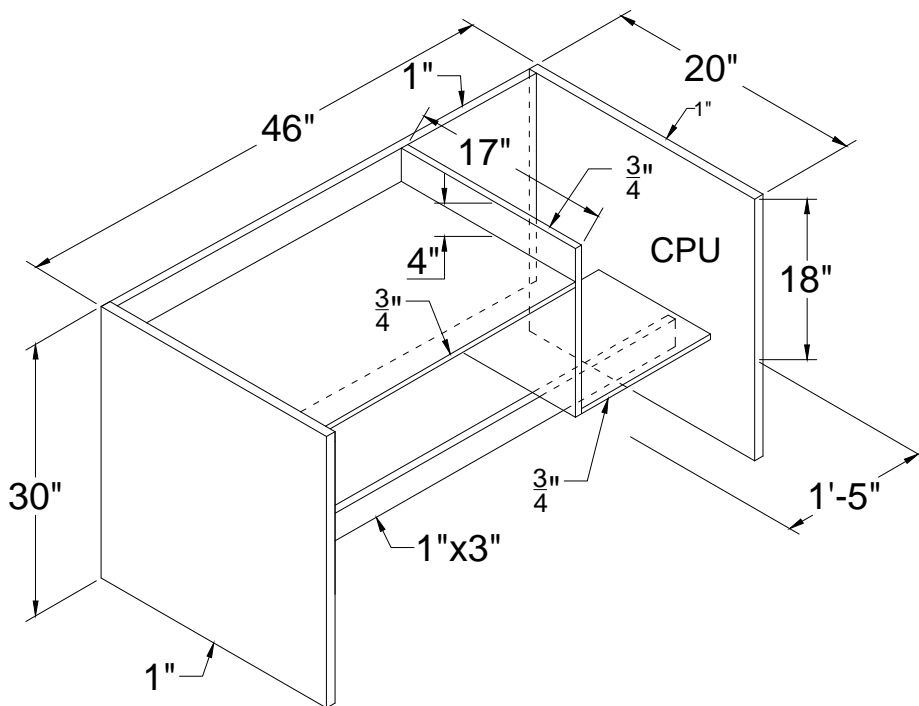
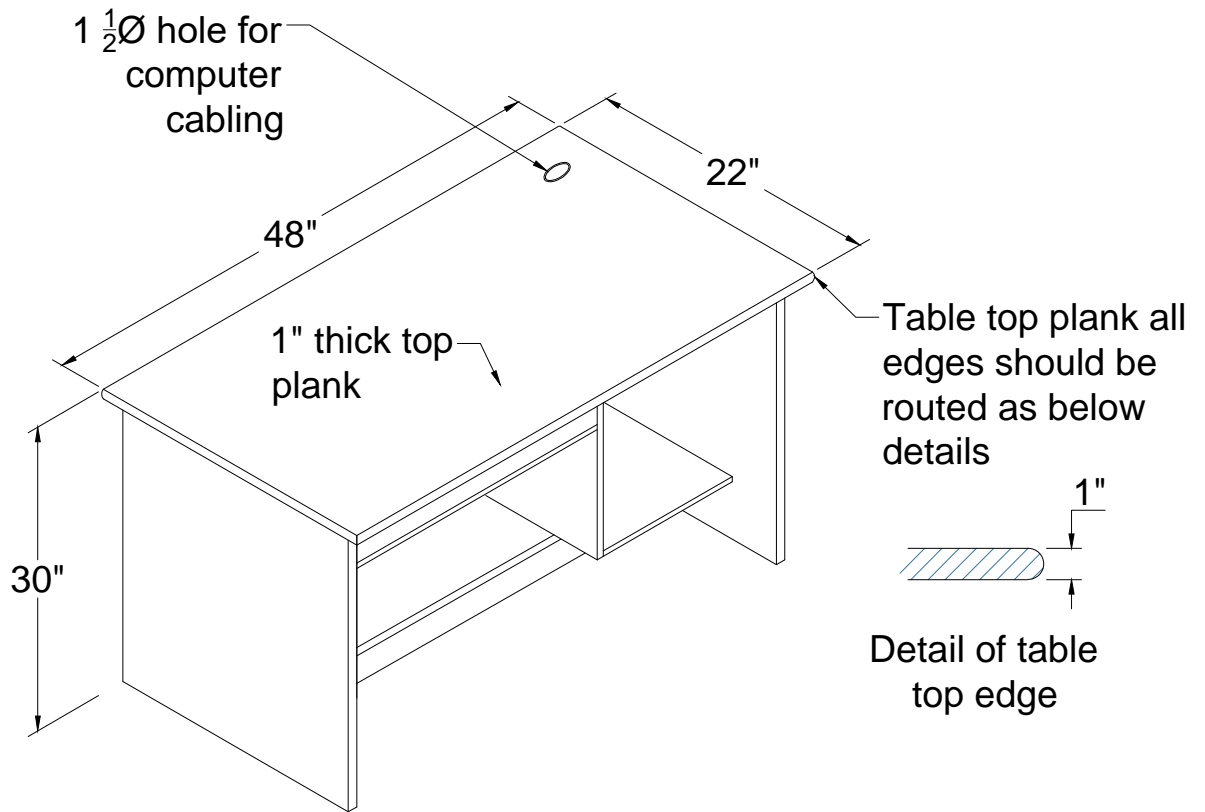

Wooden Lecture Room Table

Appendix 10.9

Specification: Wooden Lecturer's Office Table-13 Nos

Item No.	Specification	Requirements	Conformity		If No, Bidder's Response
			Yes	No	
1	Table top size (W x L)	5'-0" x 3'-3"			
2	Table height (H)	2'-6"			
3	Drawers	Three drawers (One lockable) with a brass lock			
4	Finishing	Finishing thickness of furniture must be exactly equal or better to the size indicated in the image, and will be rejected if any deviations found			
		All nails and screws should be brass			
		All stains and finishes applied shall be water base and of the highest quality available in the industry. eg. JAT. TEC prior approval is required if finishes other than JAT products are used as wood preservatives stains and surfaces finishes.			
		Timber used shall be applied with wood preservatives before and after making of furniture and after Inspected by the TEC three coats of Stain teak and two layers mat surface protection layers shall be applied. After application of each stain furniture shall be applied sand paper 80,120,320 or otherwise as recommended by the manufacture of the surface coatings. Eg. JAT products.			
5	Material	Timber species - Solid teak wood, sustainably harvested from more than 30 years old forest plantations. Supplier shall furnished all the government permits for felling and transporting of the logs that goes into the making of the furniture.			
		Teak timber must be well seasoned & treated of which, moisture level must be less than 12%. Certificate for treatment /receipt of treatment of the logs for the above moisture level used for the fabrication of the furniture shall be provided by the supplier.			
		Usage of SAP wood must be less than 10%. To ensure this condition the products should be presented to the University appointed Technical Evaluation Committee for their approval before the application of stains and application any other surface protection and appearance enhancement agents. Only those samples that were provisionally approved will be finally checked and accepted against the sample for payments.			
6	Other	Please specify.			

	specification				
7	Warranty (if any condition please specify)	Minimum warranty period must be 5 years			
8	Other	Supplier should agree that the placement of purchase order is subjected to submission of the sample within 7 days after the request and attending to any defects correction of the sample within 7 days from the submission of the sample. Note. University reserve the right to reject the samples that do not comply with the above deadlines and collect sample and award the contract to the next recommended bidder by the TEC (Technical Evaluation Committee).			
		All final purchases shall confirm to the quality and workmanship of the sample submitted and checked and approved before the placement of the order.			
		Bidders must have more than 5 years' experience in wood industry (Proof documents must be attached)			
		Proof Documents with contact details as attached for 5 years' experience of supplying similar furniture items			

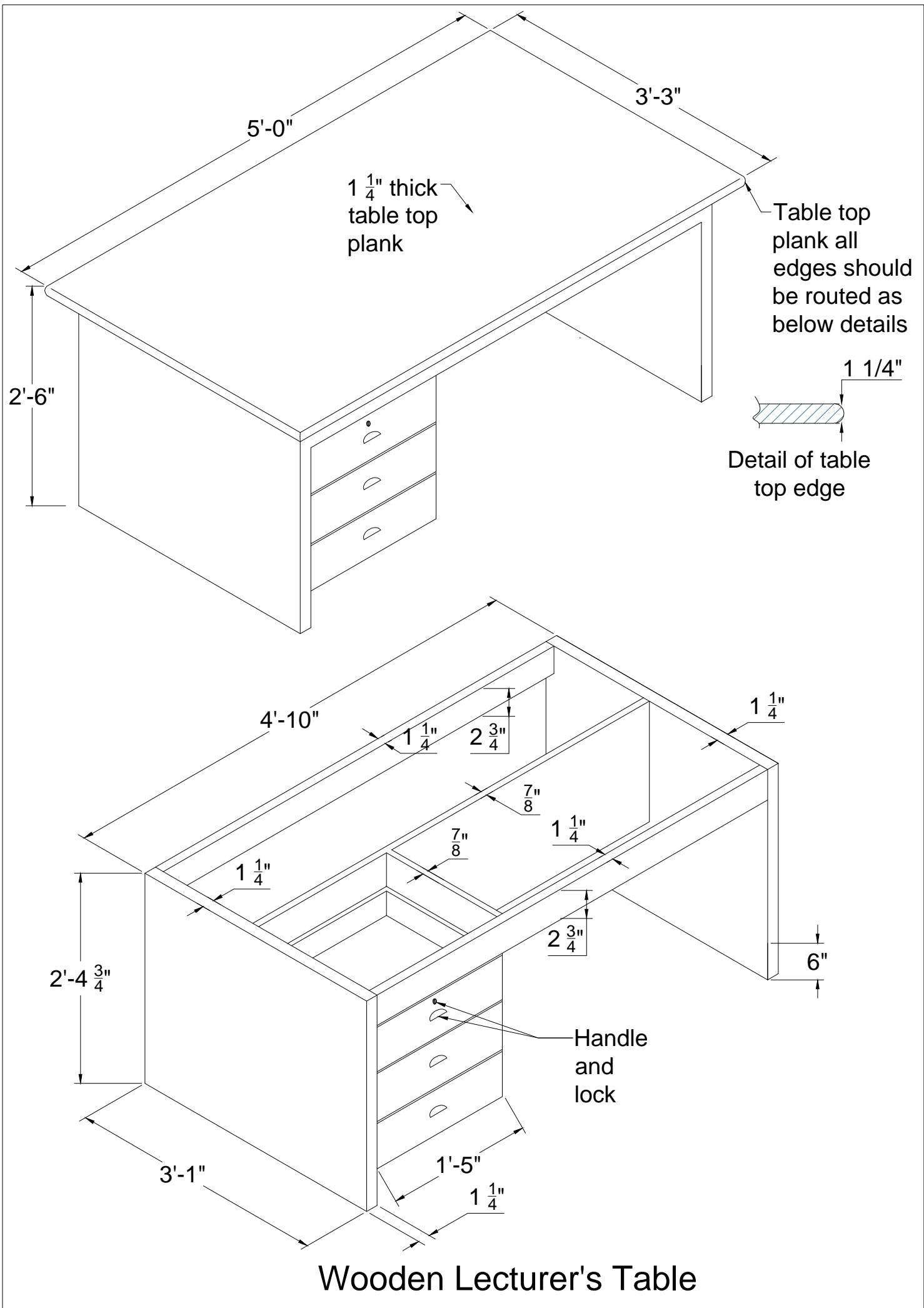

Appendix 10.10

Specification: Executive high back chair (Rotatable) - 10 Nos

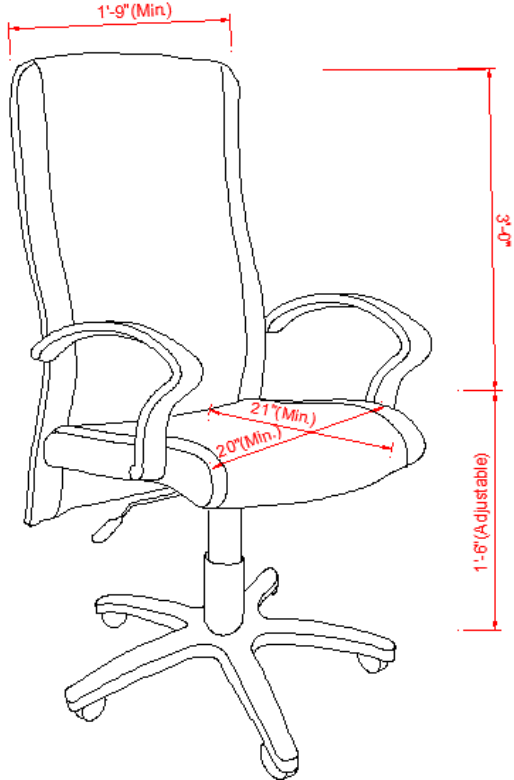
Item No.	Specification	Requirements	Conformity		If No, Bidder's Response
			Yes	No	
1	Seat size	Min. 20" x 21" (Rotatable)			
2	Height	Adjustable			
3	Seat type	Fabric Cushion shown in the picture Specify the material			
4	Back rest size	High back as shown in the picture.(Min. 21"x 36")			
5	Chair legs	Five legs with wheels			
6	Structure	Corrosion resistant steel (Specify treatment)			
7	Plastic structural components	Specify material			
8	Colour	Black			
9	Other specification	Please specify.			
10	Warranty (specify conditions)	3 years comprehensive			
11	Other	A sample of the chair to the given specification should be submitted to evaluation when the supplier is informed.			
12	Drawing	 <p>Technical drawing of an executive high back chair with the following dimensions:</p> <ul style="list-style-type: none"> Backrest width: 1'-9" (Min) Backrest height: 3'-0" Seat width: 21" (Min) Seat depth: 20" (Min) Seat height: 1'-6" (Adjustable) 			

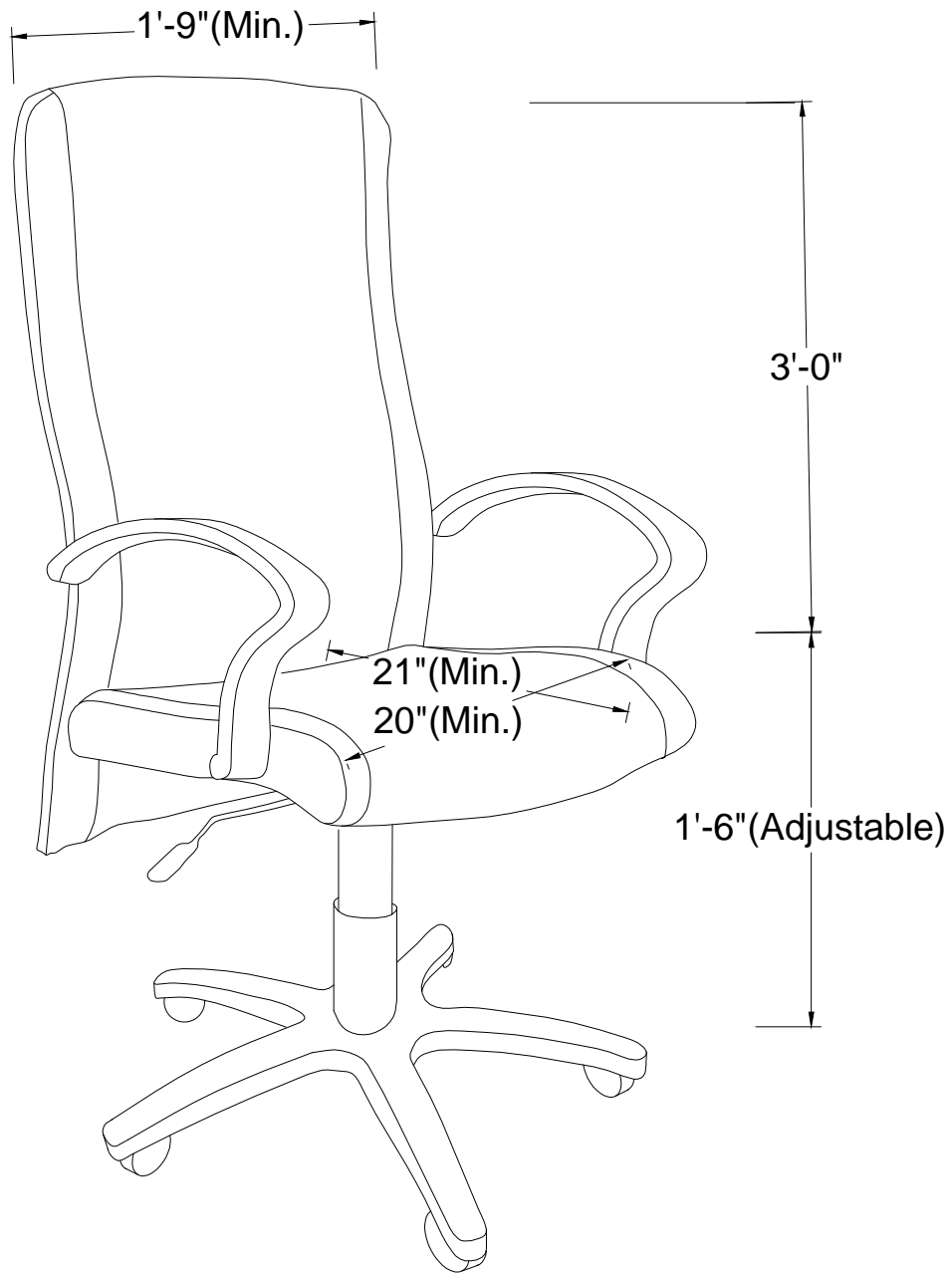

**Adjustable Executive Chair
(Cushion chair)**

Appendix 10.11

Specification: Wooden rack - 20 Nos

Item No.	Specification	Requirements	Conformity		If No, Bidder's Response
			Yes	No	
1	Rack top size (W x L)	3'-0" x 2'-4"			
2	Rack height (H)	3'-3"			
3	Shelves	As given drawing			
4	Finishing	Finishing thickness of furniture must be exactly equal or better to the size indicated in the image, and will be rejected if any deviations found			
		All nails and screws should be brass			
		All stains and finishes applied shall be water base and of the highest quality available in the industry. eg. JAT. TEC prior approval is required if finishes other than JAT products are used as wood preservatives stains and surfaces finishes.			
		Timber used shall be applied with wood preservatives before and after making of furniture and after Inspected by the TEC three coats of Stain teak and two layers mat surface protection layers shall be applied. After application of each stain furniture shall be applied sand paper 80,120,320 or otherwise as recommended by the manufacture of the surface coatings. Eg. JAT products.			
5	Material	Timber species - Solid teak wood, sustainably harvested from more than 30 years old forest plantations. Supplier shall furnished all the government permits for felling and transporting of the logs that goes into the making of the furniture.			
		Teak timber must be well seasoned & treated of which, moisture level must be less than 12%. Certificate for treatment /receipt of treatment of the logs for the above moisture level used for the fabrication of the furniture shall be provided by the supplier.			
		Usage of SAP wood must be less than 10%. To ensure this condition the products should be presented to the University appointed Technical Evaluation Committee for their approval before the application of stains and application any other surface protection and appearance enhancement agents. Only those samples that were provisionally approved will be finally checked and accepted			

		against the sample for payments.			
6	Other specification	Please specify.			
	Warranty (if any condition please specify)	Minimum warranty period must be 5 years			
7	Other	Supplier should agree that the placement of purchase order is subjected to submission of the sample within 7 days after the request and attending to any defects correction of the sample within 7 days from the submission of the sample. Note. University reserve the right to reject the samples that do not comply with the above deadlines and collect sample and award the contract to the next recommended bidder by the TEC (Technical Evaluation Committee).			
		All final purchases shall confirm to the quality and workmanship of the sample submitted and checked and approved before the placement of the order.			
		Bidders must have more than 5 years experience in wood industry (Proof documents must be attached)			
		Proof Documents with contact details as attached for 5 years' experience of supplying similar furniture items			

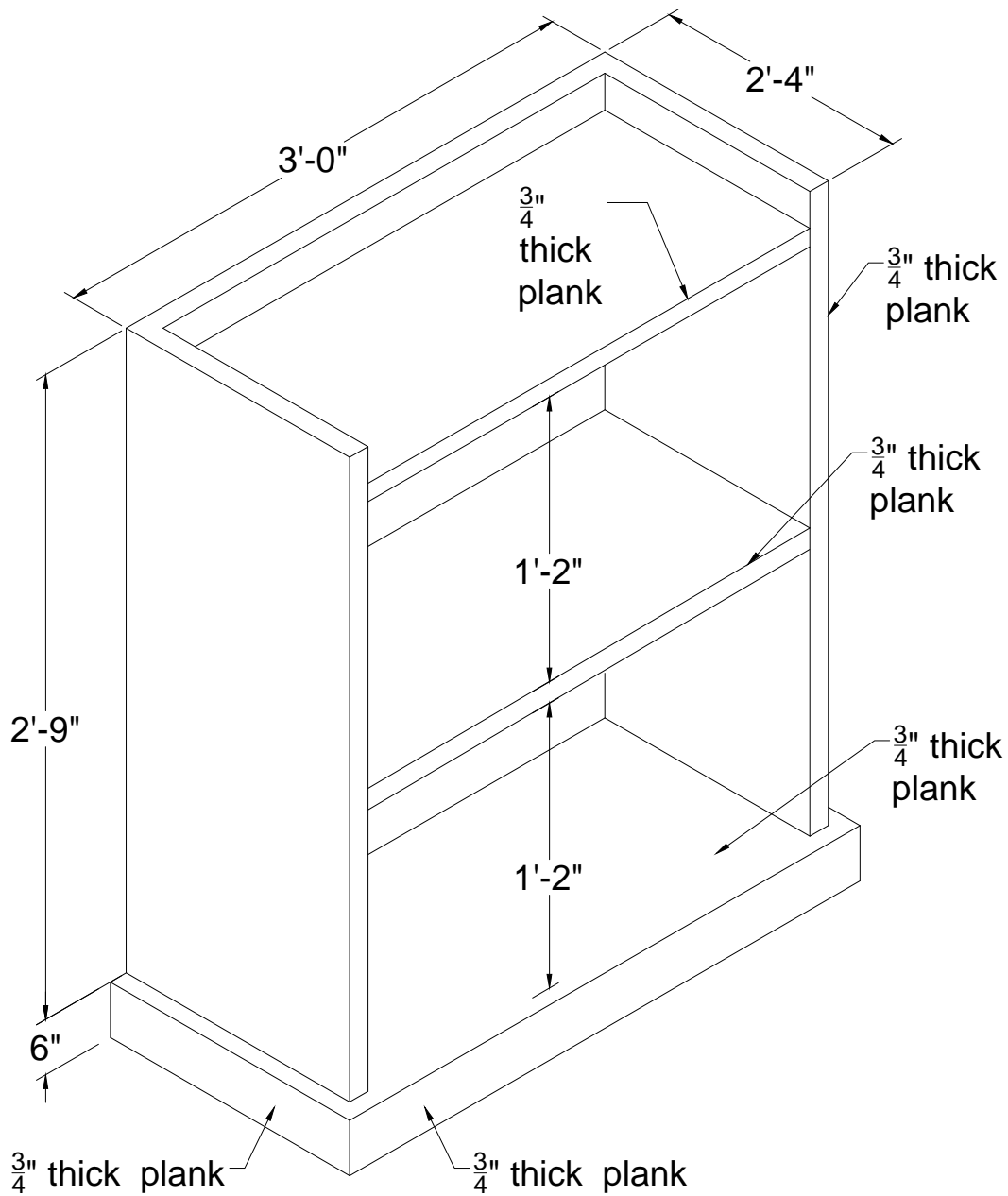

Wooden Rack

Appendix 10.12

Specification: Lecture Room Study Table - 150 Nos

Item No.	Specification	Requirements	Conformity		If No, Bidder's Response
			Yes	No	
1	Table top size (W x L)	2'-0" x 1'-10"			
2	Table height (H)	2'-6"			
3	Cupboards and Drawers	No			
4	Finishing	Finishing thickness of furniture must be exactly equal or better to the size indicated in the image, and will be rejected if any deviations found			
		All nails and screws should be brass			
		All stains and finishes applied shall be water base and of the highest quality available in the industry. eg. JAT. TEC prior approval is required if finishes other than JAT products are used as wood preservatives stains and surfaces finishes.			
		Timber used shall be applied with wood preservatives before and after making of furniture and after Inspected by the TEC three coats of Stain teak and two layers mat surface protection layers shall be applied. After application of each stain furniture shall be applied sand paper 80,120,320 or otherwise as recommended by the manufacture of the surface coatings. Eg. JAT products.			
5	Material	Timber species - Solid teak wood, sustainably harvested from more than 30 years old forest plantations. Supplier shall furnished all the government permits for felling and transporting of the logs that goes into the making of the furniture.			
		Teak timber must be well seasoned & treated of which, moisture level must be less than 12%. Certificate for treatment /receipt of treatment of the logs for the above moisture level used for the fabrication of the furniture shall be provided by the supplier.			
		Usage of SAP wood must be less than 10%. To ensure this condition the products should be presented to the University appointed Technical Evaluation Committee for their approval before the application of stains and application any other surface protection and appearance enhancement agents. Only those samples that were provisionally approved will be finally checked and accepted against the sample for			

		payments.			
6	Other specification	Please specify.			
7	Warranty (if any condition please specify)	Minimum warranty period must be 5 years			
8	Other	Supplier should agree that the placement of purchase order is subjected to submission of the sample within 7 days after the request and attending to any defects correction of the sample within 7 days from the submission of the sample. Note. University reserve the right to reject the samples that do not comply with the above deadlines and collect sample and award the contract to the next recommended bidder by the TEC (Technical Evaluation Committee).			
		All final purchases shall confirm to the quality and workmanship of the sample submitted and checked and approved before the placement of the order.			
		Bidders must have more than 5 years' experience in wood industry (Proof documents must be attached).			
		Proof Documents with contact details as attached for 5 years' experience of supplying similar furniture items.			

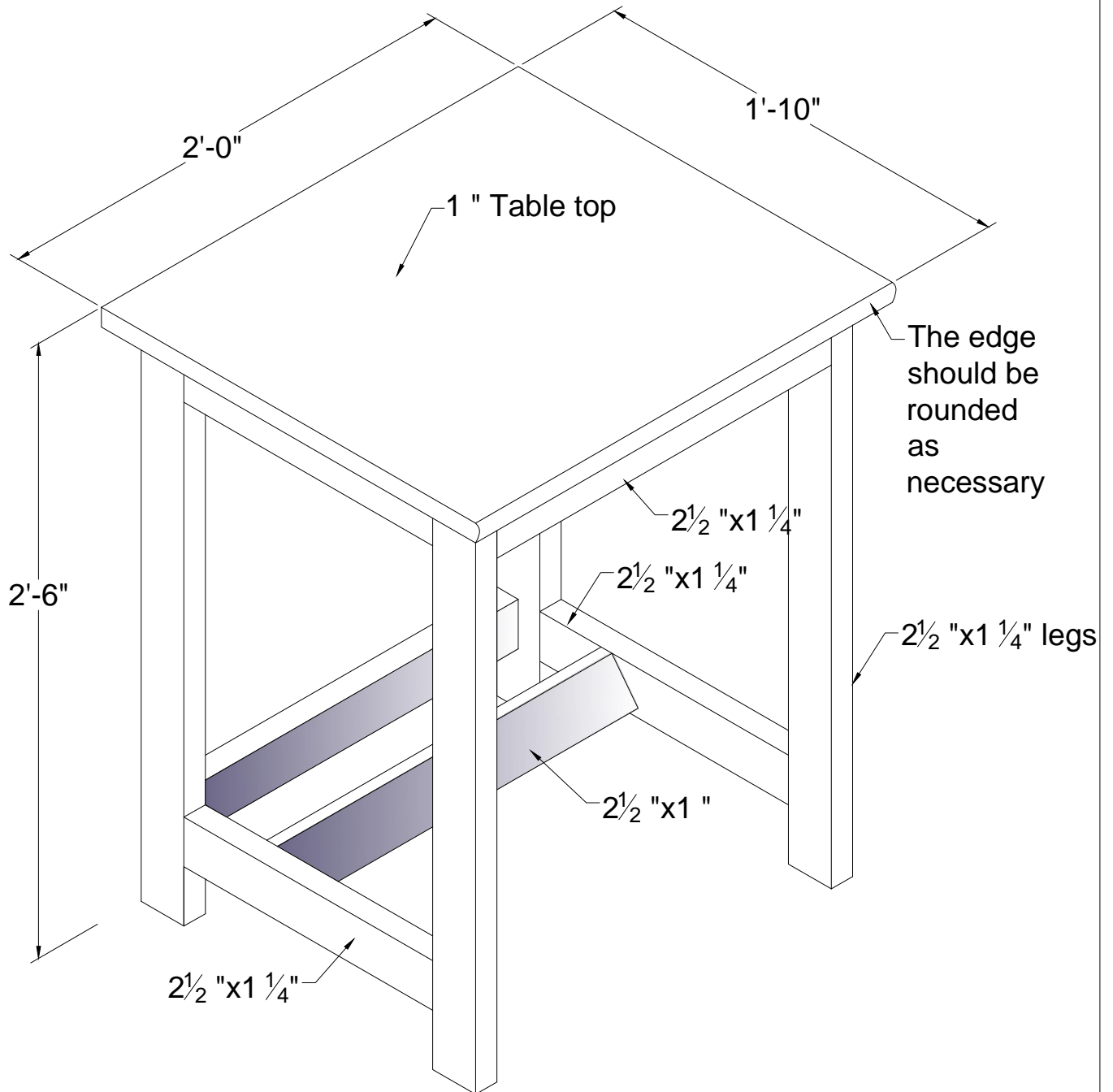

Student Table

Appendix 10.13

Specification: Canteen Tables - 18 Nos

Item No.	Specification	Requirements	Conformity		If No, Bidder's Response
			Yes	No	
1	Table top	6'-0" x 1'-10" smoothly finished fiber table top plank (Black colour)			
2	Table height (H)	2'-6"			
3	Cupboards and Drawers	No			
4	Finishing	Finishing thickness of furniture must be exactly equal or better to the size indicated in the image, and will be rejected if any deviations found			
		All nails and screws should be brass			
		All stains and finishes applied shall be water base and of the highest quality available in the industry. eg. JAT. TEC prior approval is required if finishes other than JAT products are used as wood preservatives stains and surfaces finishes.			
		Timber used shall be applied with wood preservatives before and after making of furniture and after Inspected by the TEC three coats of Stain teak and two layers mat surface protection layers shall be applied. After application of each stain furniture shall be applied sand paper 80,120,320 or otherwise as recommended by the manufacture of the surface coatings. Eg. JAT products.			
5	Material	Timber species - Solid teak wood, sustainably harvested from more than 30 years old forest plantations. Supplier shall furnished all the government permits for felling and transporting of the logs that goes into the making of the furniture.			
		Teak timber must be well seasoned & treated of which, moisture level must be less than 12%. Certificate for treatment /receipt of treatment of the logs for the above moisture level used for the fabrication of the furniture shall be provided by the supplier.			
		Usage of SAP wood must be less than 10%. To ensure this condition the products should be presented to the University appointed Technical Evaluation Committee for their approval before the application of stains and application any other surface protection and appearance enhancement agents. Only those samples that were provisionally approved will be finally checked and accepted			

		against the sample for payments.			
6	Other specification	Please specify.			
	Warranty (if any condition please specify)	Minimum warranty period must be 5 years			
7	Other	Supplier should agree that the placement of purchase order is subjected to submission of the sample within 7 days after the request and attending to any defects correction of the sample within 7 days from the submission of the sample. Note. University reserve the right to reject the samples that do not comply with the above deadlines and collect sample and award the contract to the next recommended bidder by the TEC (Technical Evaluation Committee).			
		All final purchases shall confirm to the quality and workmanship of the sample submitted and checked and approved before the placement of the order.			
		Bidders must have more than 5 years experience in wood industry (Proof documents must be attached)			
		Proof Documents with contact details as attached for 5 years' experience of supplying similar furniture items			

Appendix 10.14

Specification: Canteen Chairs - 100 Nos

Item No.	Specification	Requirements	Conformity		If No, Bidder's Response
			Yes	No	
1	Chair size (W x L)	As shown drawing			
2	Backrest	Comfortable curved wooden			
3	Seat	Front edge rounded wooden			
4	Finishing	Finishing thickness of furniture must be exactly equal or better to the size indicated in the image, and will be rejected if any deviations found			
		All nails and screws should be brass			
		All stains and finishes applied shall be water base and of the highest quality available in the industry. eg. JAT. TEC prior approval is required if finishes other than JAT products are used as wood preservatives stains and surfaces finishes.			
		Timber used shall be applied with wood preservatives before and after making of furniture and after Inspected by the TEC three coats of Stain teak and two layers mat surface protection layers shall be applied. After application of each stain furniture shall be applied sand paper 80,120,320 or otherwise as recommended by the manufacture of the surface coatings. Eg. JAT products.			
5	Material	Timber species - Solid teak wood, sustainably harvested from more than 30 years old forest plantations. Supplier shall furnished all the government permits for felling and transporting of the logs that goes into the making of the furniture.			
		Teak timber must be well seasoned & treated of which, moisture level must be less than 12%. Certificate for treatment /receipt of treatment of the logs for the above moisture level used for the fabrication of the furniture shall be provided by the supplier.			
		Usage of SAP wood must be less than 10%. To ensure this condition the products should be presented to the University appointed Technical Evaluation Committee for their approval before the application of stains and application any other surface protection and appearance enhancement agents. Only those samples that were provisionally approved will be finally checked and accepted against the sample for payments.			
6	Other specification	Please specify.			

7	Warranty (if any condition please specify)	Minimum warranty period must be 5 years			
8	Other	Supplier should agree that the placement of purchase order is subjected to submission of the sample within 7 days after the request and attending to any defects correction of the sample within 7 days from the submission of the sample. Note. University reserve the right to reject the samples that do not comply with the above deadlines and collect sample and award the contract to the next recommended bidder by the TEC (Technical Evaluation Committee).			
		All final purchases shall confirm to the quality and workmanship of the sample submitted and checked and approved before the placement of the order.			
		Bidders must have more than 5 years experience in wood industry (Proof documents must be attached)			
		Proof Documents with contact details as attached for 5 years' experience of supplying similar furniture items			

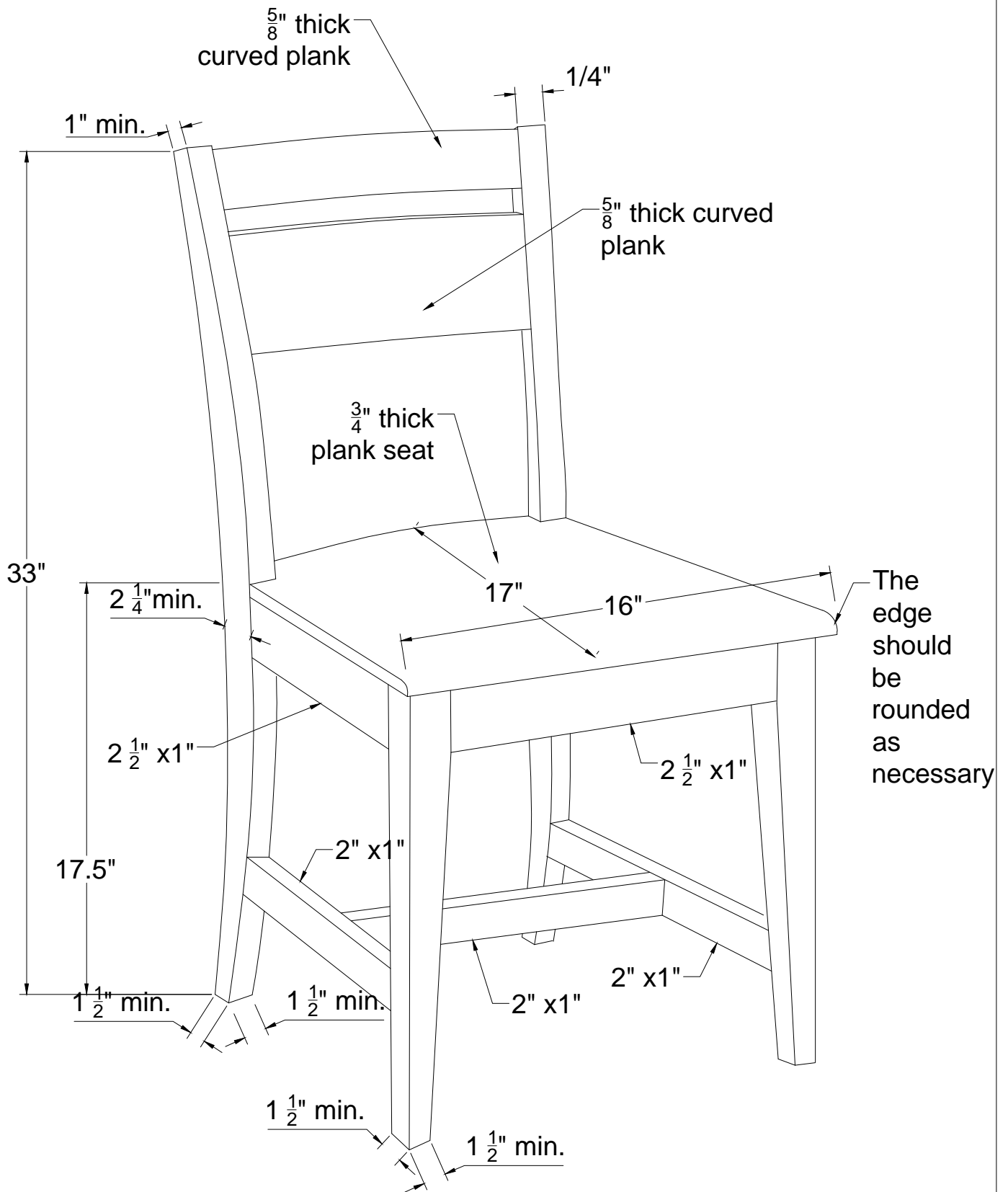

Wooden Dining Chair
 for Canteen

Appendix 10.15

Specification for Wooden Platforms for Lecture Rooms - 03 Nos

Item No.	Specification	Requirements	Conformity		If No, Bidder's Response
			Yes	No	
1	Platform size (W x L)	6'-0"x 16'-0"			
2	Platform height (H)	0' - 9"			
3	Finishing	Finishing thickness of furniture must be exactly equal or better to the size indicated in the image, and will be rejected if any deviations found			
		All stains and finishes applied shall be water base and of the highest quality available in the industry. eg. JAT. TEC prior approval is required if finishes other than JAT products are used as wood preservatives stains and surfaces finishes.			
		Timber used shall be applied with wood preservatives before and after making of furniture and after Inspected by the TEC three coats of Stain teak and two layers mat surface protection layers shall be applied. After application of each stain furniture shall be applied sand paper 80,120,320 or otherwise as recommended by the manufacture of the surface coatings. Eg. JAT products.			
4	Material	Timber species - Solid Mahogani wood, sustainably harvested from more than 20 years old forest plantations. Supplier shall furnished all the government permits for felling and transporting of the logs that goes into the making of the furniture.			
		Mahogani timber must be well seasoned & treated of which, moisture level must be less than 12%. Certificate for treatment /receipt of treatment of the logs for the above moisture level used for the fabrication of the furniture shall be provided by the supplier.			
		Usage of SAP wood must be less than 10%. To ensure this condition the products should be presented to the University appointed Technical Evaluation Committee for their approval before the application of stains and application any other surface protection and appearance enhancement agents. Only those samples that were provisionally approved will be finally checked and accepted against the			

		sample for payments.			
5	Other specification	Please specify.			
6	Warranty (if any condition please specify)	Minimum warranty period must be 3 years			
7	Other	Supplier should agree that the placement of purchase order is subjected to submission of the sample within 7 days after the request and attending to any defects correction of the sample within 7 days from the submission of the sample. Note. University reserve the right to reject the samples that do not comply with the above deadlines and collect sample and award the contract to the next recommended bidder by the TEC (Technical Evaluation Committee).			
		All final purchases shall confirm to the quality and workmanship of the sample submitted and checked and approved before the placement of the order.			
		Bidders must have more than 5 years experience in wood industry (Proof documents must be attached)			
		Proof Documents with contact details as attached for 5 years' experience of supplying similar furniture items			

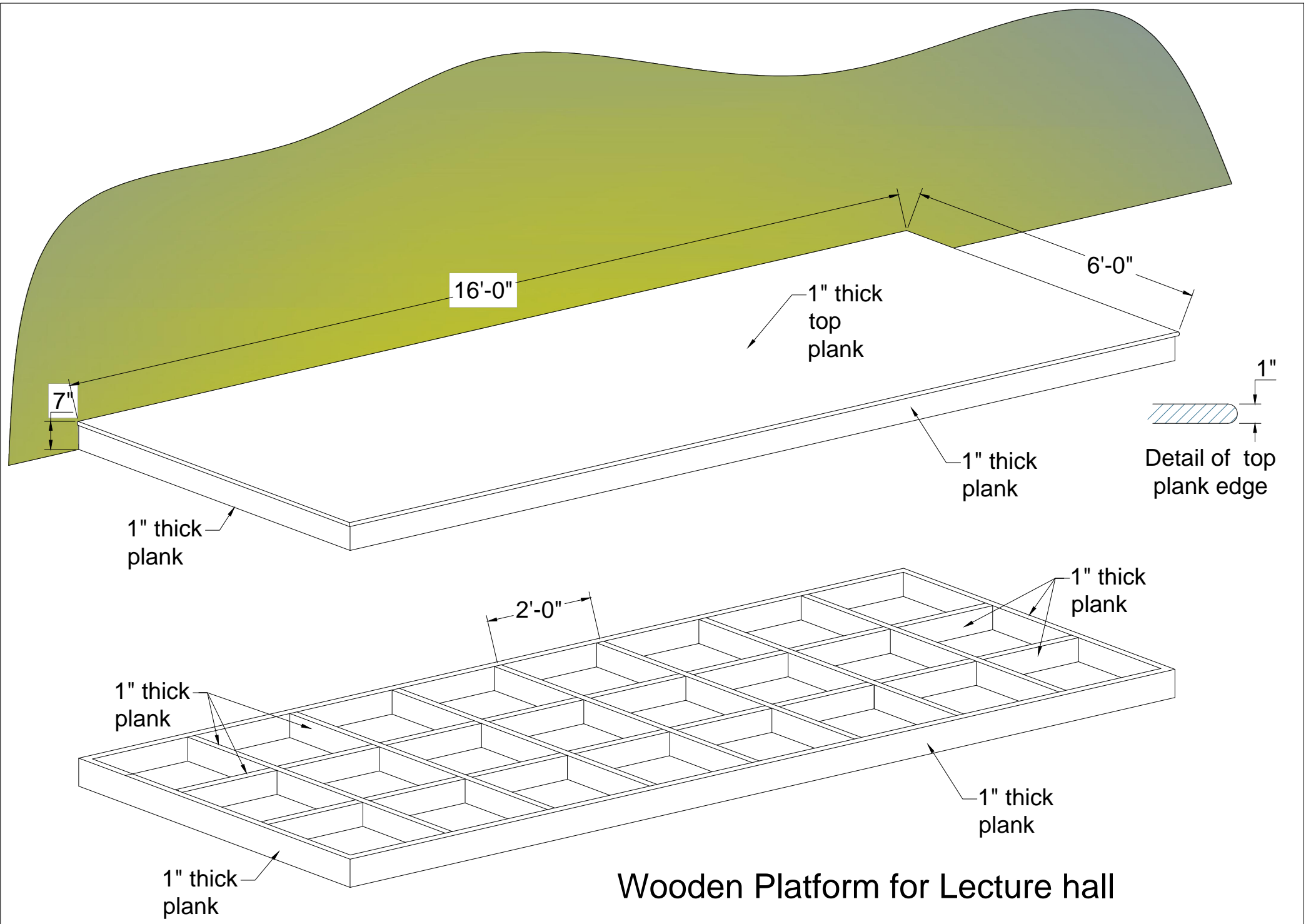

Wooden Platform for Lecture hall

Appendix 10.16

Specification for Pigeon hole rack - 01 Nos

Item No	Specification	Requirements	Conformity		If No, Bidder's Response
			Yes	No	
1	Rack size (W x L x H)	30 cm x 90 cm x 150 cm			
2	Other dimensions	As in the attached drawing			
3	Finishing	Finishing thickness of furniture must be exactly equal or better to the size indicated in the image, and will be rejected if any deviations found			
		All nails and screws should be brass			
		All stains and finishes applied shall be water base and of the highest quality available in the industry. eg. JAT. TEC prior approval is required if finishes other than JAT products are used as wood preservatives stains and surfaces finishes.			
		Timber used shall be applied with wood preservatives before and after making of furniture and after Inspected by the TEC three coats of Stain teak and two layers mat surface protection layers shall be applied. After application of each stain furniture shall be applied sand paper 80,120,320 or otherwise as recommended by the manufacture of the surface coatings. Eg. JAT products.			
4	Material	Timber species - Solid teak wood, sustainably harvested from more than 30 years old forest plantations. Supplier shall furnished all the government permits for felling and transporting of the logs that goes into the making of the furniture.			
		Teak timber must be well seasoned & treated of which, moisture level must be less than 12%. Certificate for treatment /receipt of treatment of the logs for the above moisture level used for the fabrication of the furniture shall be provided by the supplier.			

		Usage of SAP wood must be less than 10%. To ensure this condition the products should be presented to the University appointed Technical Evaluation Committee for their approval before the application of stains and application any other surface protection and appearance enhancement agents. Only those samples that were provisionally approved will be finally checked and accepted against the sample for payments.			
5	Other specification	Please specify.			
6	Warranty (if any condition please specify)	Minimum warranty period must be 5 years			
7	Other	Supplier should agree that the placement of purchase order is subjected to submission of the sample within 7 days after the request and attending to any defects correction of the sample within 7 days from the submission of the sample. Note. University reserve the right to reject the samples that do not comply with the above deadlines and collect sample and award the contract to the next recommended bidder by the TEC (Technical Evaluation Committee).			
		All final purchases shall confirm to the quality and workmanship of the sample submitted and checked and approved before the placement of the order.			
		Bidders must have more than 5 years experience in wood industry (Proof documents must be attached)			
		Proof Documents with contact details as attached for 5 years experience of supplying similar furniture items			

